

Fast Bilateral Filter Technique for 3D-HEVC Standard

Delaram Amiri, Mohamed El-Sharkawy and Brian King

Abstract— This paper introduces the design of in-loop filtering with Fast Bilateral Filter for 3D-HEVC standard. Bilateral filter is a filter that smoothes an image while preserving strong edges and it can remove the artifacts in an image. In this paper, performance of bilateral filter in picture based level for 3D-HEVC is evaluated. Test model HTM- 6.2 is used to demonstrate the results. Results show up to of 20 percent of reduction in processing time of 3D-HEVC with minimal effect on the quality of test sequences.

Index Terms— Fast Bilateral Filter, HEVC

I. INTRODUCTION

IN recent years the interest for 3D television (3DTV) has been increased significantly. While stereo displays with glasses require 2 views, auto-stereoscopic displays does not require glasses [1]. JCT-3V has developed 3D extension to HEVC to support auto-stereoscopic displays. HEVC encoding process starts with splitting the signal into rectangular blocks called coding tree units (CTUs), predicted from previously decoded data. After applying block transformation based on integer approximation of discrete cosine transformation, quantization and coding of the transform coefficients will be done. HEVC coding scheme uses block-based hybrid coding architecture, combining motion-compensated prediction and transform coding with high-efficiency entropy coding. Therefore, discontinuities can occur in the reconstructed signal at the block boundaries. Visible discontinuities at the block boundaries are known as blocking artifacts. Block-transform coding of the prediction error followed by coarse quantization is the major reason of blocking artifacts [2]. One of the approaches to improve the blocking artifacts is in-loop filtering. Since the filter is placed within the loop, improving artifacts effects not only the quality of the output pictures but also the reference pictures for prediction when coding current pictures. Therefore, loop filters have an essential impact on the performance of the video coding scheme [3]. Test model of HM6.2 contains three in-loop filtering blocks: deblocking filter (DF), sample adaptive offset (SAO), and ALF. In this paper, a bilateral filter in picture based for texture view is implemented and added to in-loop filtering block to reduce the artifacts in encoding process. Since this implementation will remove the artifacts faster than anchor test model, it will reduce the use of strong deblocking filter resulting in reduction in running time of encoder up to 20 percent with minimal change in PSNR. The rest of this paper is organized as follows. Section III discuss the Bilateral Filter

scheme. Experimental results are presented in Section IV, while Section V gives the concluding remarks. This method reduces the average running time of encoder process up to 20 percent without effecting the quality and PSNR of the video.

II. OVERVIEW OF DEBLOCKING FILTER

This section describes Deblocking Filter core technique employed in HTM 6 in 3D-HEVC. Deblocking filter is used to reduce the artifacts resulting from independent coding blocks. This filter first filters vertical edge using horizontal filter. Afterwards, horizontal edge is filtered using vertical filtering. Deblocking filtering is applied to 8x8 block boundaries. Difficult design process of deblocking filtering is to decide whether or not to filter a special block boundary and to decide on choosing a normal or a strong filter to be applied. Deblocking is applied on a block boundary when all of the following conditions are fulfilled: 1) the block boundary is either a prediction unit or transform unit boundary; 2) the boundary strength is greater than zero; and 3) changes of signal on both sides of a block boundary is below a threshold[2]

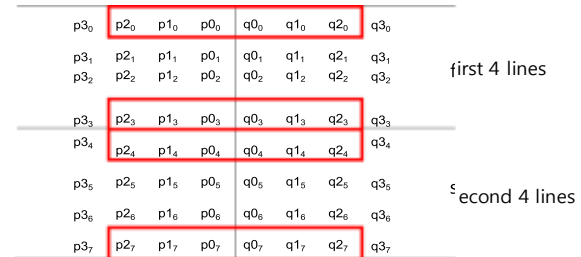

Figure 1) Red boxes represent pixels involving in filter on/off decision and strong/weak filter selection [4]

According to Figure 1 if the following is true, filtering for the first four lines is turned on and strong/weak filter selection process is applied [4]:

$$dp0 + dq0 + dp3 + dq3 < \beta \quad (1)$$

On the other hand if the following three conditions are met, strong filter is used for the first four lines,

$$2(dp0 + dq0) < (\beta / 4) \quad (2)$$

$$|p30 - p00| + |q00 - q30| < (\beta / 8) \quad (3)$$

$$|p00 - q00| < (2.5 tc) \quad (4)$$

$$2(dp3 + dq3) < (\beta / 4) \quad (5)$$

$$|p3_2 - p0_2| + |q0_2 - q3_2| < (\beta / 8) \quad (6)$$

$$|p0_2 - q0_2| < (2.5 tc) \quad (7)$$

If following two conditions are met, strong filter is used for filtering of the second 4 lines. Otherwise, weak filter is used [4].

$$2(dp4 + dq4) < (\beta / 4) \quad (8)$$

$$|p3_4 - p0_4| + |q0_4 - q3_4| < (\beta / 8) \quad (9)$$

$$|p0_4 - q0_4| < (2.5 tc) \quad (10)$$

$$2(dp7 + dq7) < (\beta / 4) \quad (11)$$

$$|p3_7 - p0_7| + |q0_7 - q3_7| < (\beta / 8) \quad (12)$$

$$|p0_7 - q0_7| < (2.5 tc) \quad (13)$$

Where,

$$dp0 = |p2,0 - 2 * p1,0 + p0,0| \quad (14)$$

$$dp3 = |p2,3 - 2 * p1,3 + p0,3| \quad (15)$$

$$dp4 = |p2,4 - 2 * p1,4 + p0,4| \quad (16)$$

$$dq0 = |q2,0 - 2 * q1,0 + q0,0| \quad (17)$$

$$dq3 = |q2,3 - 2 * q1,3 + q0,3| \quad (18)$$

$$dq7 = |q2,7 - 2 * q1,7 + q0,7| \quad (19)$$

Threshold β and tc used in filter on/off decision, strong and weak filter selection and weak filtering process are derived based on value of two neighboring blocks with common block edge.

III. OVERVIEW OF FAST BILATERAL FILTER

This section describes Fast Bilateral Filter method used for 3D-HEVC for in-loop filtering implementation. Bilateral filter is a nonlinear filter that smoothes an image during which it preserves the strong edges. Since Bilateral Filter can eliminate the artifacts in an image, it can be used as a part of in-loop-filtering block in 3D-HEVC. In Bilateral Filter, a pixel is replaced by a weighted average of its neighbors. The idea is that since neighbor pixels are probable to be correlated due to small variation in an image, it is reasonable to find the mean of the near pixels. In contrast, noise corrupting near pixels are less correlated, so impact of noise will be reduced by averaging the neighbors. This Bilateral Filtering process can be slow [5]:

Figure 2 shows the encoder block diagram of this implementation. In this design, the picture is split into block-shaped regions. The reference picture is coded using intra-picture prediction which uses the closest data related to the region of the reference image. The encoding process of inter-picture prediction chooses data related to the reference frame and motion vector (MV) to be done for predicting each block.

Afterwards, the residual between the original block and its prediction(inter or intra prediction) is transformed using a linear spatial transform. The transform coefficients are quantized, entropy coded, and sent with the prediction information to the decoder.

The quantized coefficients are inverse quantized and inverse transformed and would be reconstructed to be used in prediction unit. reconstructed signal is also sent to the in-loop filtering to be smoothed.

After in-loop filtering the picture will be saved in a picture buffer to be used for the prediction of further pictures. As can be seen, loop filter is functioning as a feedback for prediction unit. Since loop filter can remove the artifacts, it has an important role in the quality of the image and improving the quality of the reference picture results in improvement of dependent coded pictures. This design, contains four in-loop filtering blocks: fast bilateral filter (FBF), deblocking filter (DF), sample adaptive offset (SAO), and Adaptive Loop Filter (ALF). FBF is located at the first stage of filtering process to reduce artifacts for each picture. DF uses predefined filters. In contrast, SAO and ALF exploit the original pixels of the current picture to reduce the average difference between the original pixels and the reconstructed pixels by adding an offset and by applying a finite impulse response (FIR) filter, respectively, with coded side information signaling the offsets and filter coefficients. ALF is applied at the last processing stage of each picture and is considered as a tool trying to catch and fix artifacts created by the previous stages [6]. In order to decrease the processing time of in-loop filtering, Fast Bilateral Filter is used as an approximation for the Bilateral Filter. This method uses downsampling in intensity and space of the signal. While interpreting the bilateral filter in terms of signal processing in a higher dimensional space, it improves the accuracy [5].

Strong Deblocking Filter affects three pixels using four pixels on each side of the block boundary. On the other hand, weak Deblocking Filter affects at most two pixels using three pixels on each side of the block boundary. This concept means that the more the use of the strong filter the slower the process of coding.

In order to speed up the coding process, removing the artifacts using Fast Bilateral Filter just before applying Deblocking Filter is an effective method. Fast bilateral filter replaces each pixel in the image with its weighted neighbor pixels and smoothes images without effecting the strong edges which causes neighbor pixels to be more correlated.

Moreover, block boundaries in images show larger variation in neighbor pixels. Therefore, Fast Bilateral Filter removes the block boundaries to some extent which causes thresholds of block boundaries taking place in weak Deblocking Filter most of the times.

Mentioned process reduces choosing strong Deblocking Filter forcing the encoder time to reduce up to 20% with minimal change in PSNR and quality of the video. Proposed algorithm uses FBF just before Deblocking Filter and it removes the artifacts as much as possible which helps choosing weak Deblocking Filter and it reduces using strong DF leading to faster process of encoding. Later on, Sample Adaptive Offset is applied and finally ALF is used to increase PSNR of video.

For Implementation of filters we used HM 6.2. The aim of the HM encoder is mainly to provide a reference implementation of an HEVC encoder, useful as a test platform for evaluating technologies and for independent encoder or decoder development.

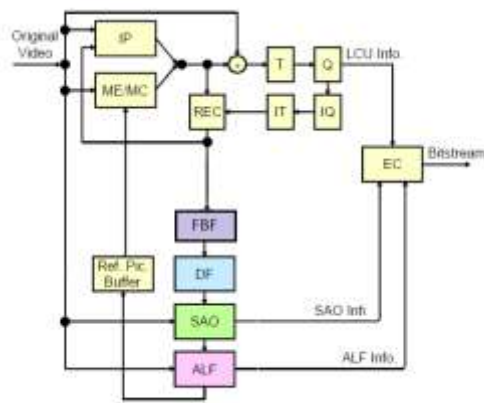

Figure 2 Block Diagram of HEVC Encoder with Fast Bilateral Filter.

IV. SIMULATION RESULTS

The 3D video test set consisted of 4 sequences with the video component in 4:2:0 chroma format: 4 with a progressive HD resolution of 1024×768 luma/depth samples with 30 fps. All 4 sequences were evaluated in two test scenarios: with ALF implementation in picture-based level, video and depth component of 3 views {V0, V1, V2} were coded and the changes in PSNR is evaluated. Test model of HTM 6.2 was used for ALF implementation. Table 1 shows the results of average improvement in PSNR of Y, U and V components for four multiview test sequences: "Balloons", "Kendo", "Newspaper" and "Lovebird1" using adaptive loop filtering method in picture-based for both depth and texture view.

Results show up to 20 percent running time reduction in the encoder with minimal changes in PSNR. The most impact has on Balloons because Balloons has less details compared to Kendo, Lovebird1 and Newspaper. Since Bilateral Filter preserves strong edges, test sequences with more details will not be effected smoothing Bilateral Filter and more number of strong DFs will be used instead of weak ones. It means that processing time for more detailed images does not decrease as much as edgy images. Generally, using Fast Bilateral Filter with ALF reduces the running time of encoder from 2 to 20 percent compared to implementation of ALF by itself. In addition, PSNR can either be decreased or increased minimally for different test sequences compared to using ALF filter. This can be helpful for the applications that running time is essential. For better understanding, with a 2013-model laptop using a single core and single thread of an Intel Core i5-3210M CPU processor clocked at 2.50 GHz for encoding an anchor 3D HEVC HM 6.2 encoder version the following is observed. To test the anchor test model, we encoded a multiview test sequence, meaning that 3 videos out of 7 videos with their corresponding depth data are encoded. This type of multiview test sequences was recorded as medium detailed scene with 7 cameras of 5cm spacing. Encoding 8 frames in each video of 3 videos with 8 frames of corresponding depth data approximately requires 2729.279 seconds (e.g. 45 minutes and 48.279 seconds). After applying mentioned algorithm that can

reduce the running time up to 20 percent (e.g. 545.85 seconds or 9 minutes and 9.85 seconds reduction for the mentioned test condition) reaching 2183.4232 seconds (36 minutes and 36.38 seconds) of encoding processing time and improve the quality of the encoded multiview test sequence at the same time. In this implementation, Inter-view is restricted to the given QP for the independent view and $QP + 3$ for all dependent views. The QP offset ΔQPD for the depth QPD in relation to the Video QP ($QPD = QP + \Delta QPD$) was fixed based on subjective assessments and varies from $\Delta QPD = 0$ for video QP = 51 at lowest quality up to $\Delta QPD = 9$ for video QP ≤ 32 at high quality. With these settings, the same encoder configuration is used for all sequences and rate points [7]. Different value of QP was tested for texture inter-view including 30, 35 and 40 with corresponding inter-view QP depth of 39, 42 and 45.

ACKNOWLEDGMENT

The authors would like to thank Fraunhofer Institute for providing 3D-HEVC software [8] and Poznan University of Technology, Poznań, Poland [9] and Nagoya University, Japan [9] for providing multiview test sequences [10].

REFERENCES

- [1] Standardized Extensions of High Efficiency Video Coding (HEVC) by: Sullivan, G.J. ; Microsoft Corp., Redmond, WA, USA ; Boyce, J.M. ; Ying Chen ; Ohm, J.-R. more authors
- [2] Norkin, Andrey, et al. "HEVC deblocking filter." *Circuits and Systems for Video Technology*, IEEE Transactions on 22.12 (2012): 1746-1754.
- [3] Wien, Mathias. "High Efficiency Video Coding." Springer, 2015. ISBN: 978-3-319-06894-7 (Print) 978-3-319-06895-4 (Online)
- [4] Kim, Il-Koo, Ken McCann, Kazuo Sugimoto, Benjamin Bross, and Woo-Jin Han. "Hm9: High efficiency video coding (HEVC) test model 9 encoder description." In 9th JCT-VC Meeting, Switzerland, pp. 10-11. 2012.
- [5] Paris, Sylvain, and Frédo Durand. "A fast approximation of the bilateral filter using a signal processing approach." *Computer Vision–ECCV 2006*. Springer Berlin Heidelberg, 2006. 568-580.
- [6] Chen, Ching-Yeh, Chia-Yang Tsai, Yu-Wen Huang, Tomoo Yamakage, In Suk Chong, Chih-Ming Fu, Takayuki Itoh et al. "The adaptive loop filtering techniques in the HEVC standard." In *SPIE Optical Engineering+ Applications*, pp. 849913-849913. International Society for Optics and Photonics, 2012.
- [7] Muller, Klaus-Robert, et al. "3D high-efficiency video coding for multi-view video and depth data." *Image Processing*, IEEE Transactions on 22.9 (2013): 3366-3378.
- [8] Fraunhofer Institute, [online]. Available: https://hevc.hhi.fraunhofer.de/svn/svn_3DVCSoftware/
- [9] Marek Domański, Tomasz Grajek, Krzysztof Klimaszewski, Maciej Kurc, Olgierd Stankiewicz, Jakub Stankowski, Krzysztof Wegner "Poznań Multiview Video Test Sequences and Camera Parameters", ISO/IEC JTC1/SC29/WG11 MPEG 2009/M17050, Xian, China, October 2009
- [10] Nagoya University, [online]. Available: <http://www.fujii.nuee.nagoya-u.ac.jp/multiview-data/>

Balloons					
	Y (dB)	U (%)	V (%)	Inter-view QP	Encoder Time %
Texture	-0.1	0	0	30	-20%
Depth	0.1	0	0	39	
Texture	-0.1	0	0	35	-10%
Depth	0.2	0	0	42	
Texture	-0.1	0	0	40	-7%
Depth	0.5	0	0	45	
Kendo					
	Y (dB)	U (dB)	V (dB)	Inter-view QP	Encoder Time %
Texture	-0.2	0	0	30	-5%
Depth	0.1	0	0	39	
Texture	-0.1	0	0	35	-5%
Depth	-0.1	0	0	42	
Texture	0.1	0	0	40	-6%
Depth	0.1	0	0	45	
Lovebird1					
	Y (dB)	U (dB)	V (dB)	Inter-view QP	Encoder Time %
Texture	0	0	0	30	-2%
Depth	0	0	0	39	
Texture	0	0	0	35	-7%
Depth	0	0	0	42	
Texture	0	0	0	40	-10%
Depth	0.1	0	0	45	
Newspaper					
	Y (dB)	U (dB)	V (dB)	Inter-view QP	Encoder Time %
Texture	-0.2	0	0	30	-2%
Depth	-0.2	0	0	39	
Texture	-0.2	0	0	35	-3%
Depth	-0.3	0	0	42	
Texture	-0.1	0	0	40	-3%
Depth	-0.3	0	0	45	

Table 1 Average PSNR changes in Luminance and Chrominance components with different QP Values