

CO₂ removal from biogas by novel micro bubble dissolving technology

[Yathip Thupglam, Navadol Laosiripojana and Nutthachi Pongprasert]

Abstract— Biogas can be used directly to generate power, but the combustion is poor due to the presence of CO₂. This paper presents the micro bubble dissolving technology as an alternative approach for CO₂ removal. The system used the micro bubble swirl-type generator to dissolved CO₂ in water. The pH meter used for study the carbon dioxide dissolved in water from micro bubble swirl-type generator with different total gas flow rate. The results showed that the change in pH decreases with increasing of total gas flow rate, but after 15 minute are stable levels that indicate the steady state of the system, water saturated with CO₂. The micro bubble dissolving technology can use to remove CO₂.

Keywords— Biogas, Micro bubble, Dissolved CO₂

I. Introduction

In the present, global energy consumption is expected to increase as result of population and economic development. On the other hand, supply of fossil fuel is perspective depletion. This raises serious issues about the balance of energy markets, as well as the raising price of fossil fuel. In addition, high emission from the combustion of fossil fuel also requires intensive controls to reduce global warming problem. Due to these described problems, it causes scientists and researcher to search for the sustainable energies as well as the method to produce useful chemicals from renewable resource. From various renewable resource biogas is one of the most promising resource because of its biological and renewable origins[1].

Biogas is the type of gas that is produced through the anaerobic degradation of organic materials. It is mostly made of methane, carbon dioxide and small amounts of some other gases. The raw biogas, the combustion is poor due to the presence of significant amount of CO₂ [2]. Reducing this compound from biogas would significantly improve the utilization of biogas, therefore, this present research aims to study the Currently, there are several technologies available e.g. water scrubbing, chemical (amine) scrubbing, and membrane separation, nevertheless, there are also several drawbacks for these technologies e.g. the high installation and operating costs of the reactor, and the need of waste management in the case of using chemical treatment [3]. This research focuses on the use of novel micro bubble dissolving technology as an alternative approach for CO₂ removal. Generally, the concept of micro bubble dissolving is to develop the nozzle system that enables to generate very small particle size of gas (with the diameter in the range of 10⁻⁶ to 10⁻⁹ m) by the swirl flows method and dissolved in the liquid. The swirl-type generator is operated with two fluids i.e. gas and liquid. The mixture of gas and water are flows into the swirl chamber in a tangential and flow through the swirl chamber to make swirl flow at the exit. The shear stress in the swirl chamber is generated by a tangential flow and pressure. The bubbles in the swirl chamber are divided to micro scale by the shear stress. The carbon dioxide dissolved in water from micro bubble generator is investigated by using pH meter.

II. Design system

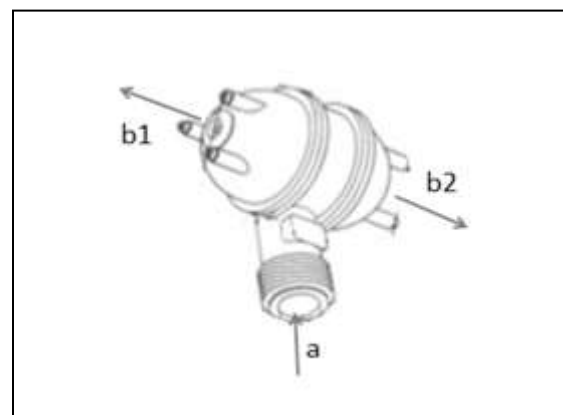

Figure 1. The micro bubble swirl-type generator

Yathip Thupglam
King Monkut's University of Technology Thonburi
Thailand

Assoc.Prof.Dr. Navadol Laosiripojana
King Monkut's University of Technology Thonburi
Thailand

Dr.Nutthachai Pongprasert
King Monkut's University of Technology Thonburi
Thailand

A. The micro bubble swirl-type generator

Figure 1. Show the micro bubble swirl-type generator (Model BT-50, Riverforest, USA). The mixture of liquid and gas are flows into the swirl chamber at point a. At point b1 and b2 are outlets of micro bubble. The minimum pressure request is 2×10^5 Pa, minimum water flow rate 26 l/min and gas flow rate 1 to 5% of water flow rate

B. DETERMINING TOTAL DYNAMIC HEAD

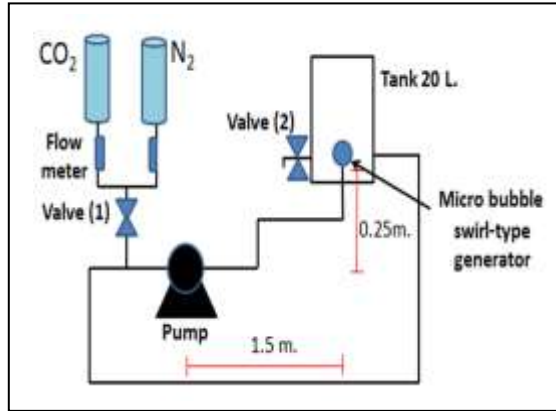

Figure 2. Schematic diagram of the experimental apparatus

The total dynamic head (TDH) consist of elevation head, friction head loss and pressure head.

- Elevation head is the vertical distance which the water must be pumped. The schematic diagram show total vertical distance is 0.25 m.
- Friction head loss is the loss of pressure due to the flow of water through pipe and fittings.

Friction head loss from flow water through pipe can be calculated by Darcy – Weisbach equation

$$h_f = f (L / D) (V^2 / 2g) \quad (1)$$

Where

h_f is the head loss due to friction

L is the length of the pipe

D is the diameter of the pipe

V is the average velocity of the fluid flow

g is the local acceleration due to gravity

f is friction factor

The equation for friction factor can be calculated by

$$f = 64/Re \quad (2)$$

Where Re is a Raynolds number.

TABEL I. The value of parameter for equation (1) and (2)

Parameter	Value
L	1.5 m.
D	25.4 mm.
V	0.43 m/s
g	9.81m/s ²
Re	151.99
f	0.42
hf	4.62 x 10 ⁻⁵

Friction head loss from flow water through equipment (Minor loss) can be calculated with

$$h_L = K (V^2 / 2g) \quad (3)$$

Where

K is the loos factor for fitting

V is the average velocity of the fluid flow

g is the local acceleration due to gravity

TABEL II. The value of loos factor for fitting

Fitting	K
Elbow,stand 90°	0.75
Globe valve	6.0

TABEL III. The value of parameter for equation (3)

Parameter	Value
V(m/s)	0.43
g (m/s ²)	9.81
h _L (m.)	1.53x10 ⁻⁵

- Pressure head is the maximum operating pressure of the water system converted from pressure to head of head. The minimum pressure of the micro bubble swirl-type generator request is 2×10^5 Pa. The pressure can be converted to head by

$$h = P / \rho g \quad (4)$$

Where

H is the head in meter

P is the pressure

ρ is the water density

g is the the local acceleration due to gravity

TABEL III. The value of parameter for equation (4)

Parameter	Value
P (Pa)	2x10 ⁵
ρ (kg/m ³)	1000
g (m/s ²)	9.81
h (m)	20

The total dynamic head (TDH) can be calculated by

$$TDH = \text{elevation head} + \text{friction head loss} + \text{pressure head} \quad (5)$$

The total dynamic head is shown in table IV

TABEL IV. The value of parameter for equation (5)

Parameter	Value
Elevation head (m)	0.25
Friction head loss (m)	6.15×10^{-5}
Pressure head (m)	20
TDH (m)	20.25

C. Pump Selection

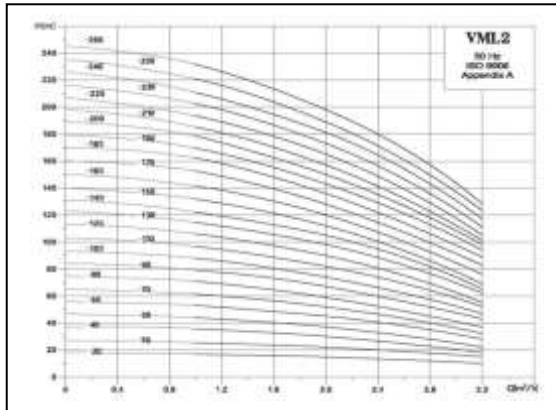

Figure 3. pump curve

The total dynamic head is 20.25 m. and the water flow rate is 26 l/min. The pump will be determined by the pump curve in figure 3 where the water flow rate and total dynamic head intersect. The pump model VML2-40 is chosen for this system.

III. Experiment

A. Apparatus

The experimental apparatus of micro-bubble system in the present work is shown in Figure 2. Overall, it consists of two flow meters to control the flow rates of carbon dioxide and nitrogen, a pump (Multi stage centrifugal pump model VML2-40 0.05kW, Stac Corporation), valve (1) to switch the gas through the reactor, gas vent to remove the gaseous phase compound out from the system, tank (20 L) as the main reactor, and valve (2) to collect water for measure the pH of water. Importantly, a Swirl-type micro-bubble generator was applied to generate small gas bubbles passing through the system.

B. pH measurement

The pH of the water was measured at tank using the pH meter (Pen type Model DPH-2 , Ataga , Japan). The pH data were measured every 5 minutes. The water sample was taken by opening of the valve at tank.

C. Gas mixture

A gas mixture containing CO₂ and N₂ with volume ratios 60:40 (N₂ 40%, CO₂ 60%) was selected to simulate the biogas. The simulated biogas passed through pipe with various total gas flow rate 500, 700 and 1000 cc/min to inlet of pump.

IV. Results and discussion

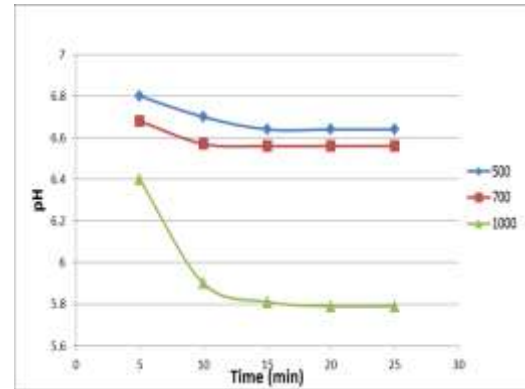

Figure 3 pH and time

A. Effect of total gas flow rate

Figure 3 shows the effects of the changes in pH for all the under various total gas flow rate. The pH value of water before running the system is 7.8. It was observed that the pH value of the water initially drops rapidly with time and. The results of experiments at the total gas flow at 1000 cc/min with 20-25 minute is minimum pH values (pH=5.8). The results showed that the change in pH decreases with increasing of total gas flow rate. The pH value is decreased by increasing of carbonic acid which is occurred by dissolution of carbon dioxide in water [4].

The levels of pH value after 15 minute are stable levels that indicate the steady state of the system, water saturated with CO₂. CO₂ is mainly dissolving gas in system because of the solubility of CO₂ higher than solubility of N₂ in the water. The pH values in this experiment can indicate only the dissolution of carbon dioxide in water.

V. Conclusion

This research focuses on the use of novel micro bubble dissolving technology as an alternative approach for CO₂ removal. The results showed the profile of decreasing pH values change with time and total gas flow rate as CO₂ dissolved. The micro bubble dissolving technology can use to remove CO₂ from the biogas. The total gas flow rate and time are important parameters for CO₂ removal in biogas.

References

- [1] M. Komiyama, T. Misonou, S. Takeuchi, K. Umetsu, J. Takahashi, Biogas as a reproducible energy source: its steam reforming for electricity generation and for farm machine fuel I.C. Ser (Ed.), Proceedings of the 2nd International Conference on Greenhouse Gases and Animal Agriculture; September 20–24, Greenhouse Gases and Animal Agriculture, Zurich, Switzerland (2006), pp. 234–237.
- [2] Stetiu, C., 1999. Energy and peak power savings potential of radiant cooling systems in US commercial buildings, *Energy and Buildings* 30, 127-138.

- [3] Tim Patterson , Sandra Esteves, Richard Dinsdale, Alan Guwy , “An evaluation of the policy and techno-economic factors affecting the potential for biogas upgrading for transport fuel use in the UK”, Energy Policy, Volume 39, Issue 3, March 2011, Pages 1806–1816
- [4] Luqman K . Abidoye, Diganta B. Das , “pH, geoelectrical and membrane flux parameters for the monitoring of water-saturated silicate and carbonate porous media contaminated by CO₂ “, Chemical Engineering Journal, Volume 262, 15 February 2015, Pages 1208–1217