

Determination of the Effects of Cement Composition on Abrasion Resistance of Cement Mortars with Artificial Neural Network

Ahmet Çavdar, Selahattin Albayrak, Şükrü Yetgin

Abstract— The abrasion resistance of a concrete and/or cement mortar is changing depending on some properties like compressive strength, matrix structure, gap ratio, aggregate type. On the other hand cement composition has also an effect on this resistance. Numerical calculation methods, originated as parallel with the developments on today's computer technology, provide a great advantage especially in prediction of experimental results. Thus, in this study, it is aimed to investigate the relationship between abrasion resistance and cement composition by using standard test methods together with predictions of Artificial Neural Networks (ANN), that is a sub-branch of Artificial Intelligence (AI). When modeling ANN, it is benefited from multi-layer ANN, which uses supervised learning rule. During training and testing stage of ANN, the results obtained from Bohme abrasion tests of cement samples having seven different compositions are used. For these samples' curing time are chosen as 7, 28, 90, 180, 270 and 360 days. By testing of ANN on conclusions, its usability, advantages and disadvantages are evaluated.

Keywords— artificial neural networks (ann), abrasion resistance, bohme abrasion method, cement composition.

I. Introduction

Artificial Neural Networks (ANNs) are relatively simple computational models based on biological neural networks (brain models). The brain basically learns from experience. It is natural proof that some problems that are beyond the scope of current computers are indeed solvable by small energy efficient packages. This brain modeling also promises a less technical way to develop machine solutions. This new approach to computing also provides a more graceful degradation during system overload than its more traditional counterparts [1-2].

These biologically inspired methods of computing are thought to be the next major advancement in the computing industry. Even simple animal brains are capable of functions that are currently impossible for computers. Computers do rote things well, like keeping ledgers or performing complex math.

Ahmet ÇAVDAR, Selahattin ALBAYRAK, Şükrü YETGİN
Gümüşhane University
Turkey

But computers have trouble recognizing even simple patterns much less generalizing those patterns of the past into actions of the future [2].

On the other hand, the abrasion resistance of concrete is relevant to essentially any application of concrete, because rubbing, scraping, skidding or sliding of objects on the concrete surface commonly occur [3]. Although much attention has been given to the bulk mechanical properties of concrete, whether in compression, tension, flexure or torsion, relatively little attention has been given to the surface mechanical properties, such as the abrasion resistance. The constitution of the concrete affects both the bulk and surface mechanical properties. Numerous admixtures (e.g., silica fume, latex and fibres) have been shown to improve the bulk mechanical properties of concrete, but the effects of many of these admixtures on the abrasion resistance of concrete have not been investigated. Silica fume is an admixture that improves the abrasion resistance of concrete [4-8]. Some researchers have also studied the ability of nano-particles to improve the abrasion resistance of concrete [9].

Numerical results show that most of the results in test set are less than the error 3% considered, the results of ANN are good agreement with experimental results.

In this study, it is aimed to investigate the relationship between abrasion resistances and cement composition by using standard test methods together with predictions of Artificial Neural Networks (ANN) that is a sub-branch of Artificial Intelligence (AI). The mortars are produced with seven different cement types composed with five different pozzolanic components. These mortars are subjected to abrasion tests six different times over the course of a year.

II. Materials and Methods

A. Materials

1) Cement Types

Seven different types of cements are used in the experimental process. These are produced by adding other components (fly ash, silica fume, natural pozzolan, blast furnace slag, limestone) to ordinary CEM I 42.5 R type cement. The compositions of the cements produced are given in Table 1. At least two compositions are comparable to each other when the compositions of the cements were chosen. The samples are named similarly to their classes in EN 197-1, for ease in identification. For example, CEM I 42.5 R is named as CI.

TABLE I. POZZOLANIC COMPOSITION OF CEMENTS (WEIGHT%)

Samples	CI	BFS	SF	NP	FA	LS
C I	100	-	-	-	-	-
C II/A-M	85	3	3	3	3	3
C II/B-M	75	5	5	5	5	5
C IV/A	70	-	5	15	10	-
C IV/B	55	-	5	20	20	-
C V/A	45	20	-	20	15	-
C V/B	35	40	-	15	10	-

2) Cement Components

The materials that constitute the cement samples are provided by different sources in Turkey. The Portland cement, ordinary CEM I 42.5 R, is derived from the Unye Cement Factory. The blast furnace slag (BFS) is obtained from Ereğli Iron-Steel Factory. The silica fume (SF) is from Antalya Eti Elektroferrokrom AS. The natural pozzolan (NP) is tuff-type rock and derived from Araklı-Trabzon District. The fly ash (FA) has siliceous fly ash properties and is obtained from the Manisa Soma Thermal Power Plant. Finally, the limestone (LS) is derived from Gumushane District. First, confirm that you have the correct template for your paper size. This template has been tailored for output on the US-letter paper size. If you are using A4-sized paper, please close this file and download the file for “MSW A4 format”.

B. Methods

1) Abrasion Test

In accordance with the objective of the study, seven different cement types are prepared. The “test mortar” consists of 450 g of the cement mixture, 1350 g of graded standard sand, and 225 g of water, and consequently the water/cement ratio is 0.50. After the moulding process, the moulds (with the mortars in them) were placed in the moist room at $23 \pm 1.7^\circ\text{C}$ for 20 to 24 h and removed at the end of this period, and the mortar cube specimens were stored in tap water until the day of testing. The abrasion tests on the mortar cubes were conducted at 7, 28, 90, 180, 270, and 360 days. The abrasion resistance of mortars is determined according to the Bohme method (in Turkish Standard of TS 699 [18]), which is the most commonly used method for determining this resistance in Europe. According to this method, the surface of the mortar is pressed on to a rotating steel plate using a constant load (Fig. 1). Twenty grams of abrasive sand is put between the mortar and the steel plate. The mortar specimen’s surface is 40 mm x 40 mm and its height is 50 mm. Subsequently, the plate is rotated 22 times and the specimen and plate are cleaned. This abrasion process is repeated 20 times for each specimen. Thus, the difference between the initial and final height of the specimen gives amount of abrasion.

2) Basic Principles of Artificial Neural Networks

The fundamental processing element of a neural network is a neuron. A neuron consists of soma, axon and dendrites which play role in entering and transmission of data. Soma controls the neuron, dendrites transmit data received other neurons with axon. Basically, a biological neuron receives inputs from other sources or neurons. Biological neuron is

abstracted when modeling Artificial Neurons. These basically consist of *inputs* (like synapses), which are multiplied by *weights* (strength of the respective signals), and then computed by a mathematical function which determines the *activation* of the neuron. Another function (which may be the identity) computes the *output* of the artificial neuron (sometimes in dependence of a certain *threshold*). ANNs combine artificial neurons in order to process information [10].

In Figure 1, various inputs to the network are represented by the mathematical symbol, G_i . Each of these inputs is multiplied by a connection weight. These weights are represented by w_{ij} . In the simplest case, these products are simply summed, fed through a transfer function to generate a result, and then output with different summing functions and activation functions [2]. Weights are changed until governing outputs are approximated to desired outputs (backpropagation method). Learning rule and required functions are adjusted to obtain the output and change of the weights.

$$W = \sum_{i=1}^n G_i w_{ij} \quad (1)$$

$$R = \frac{1}{1 + e^{-w}} \quad (2)$$

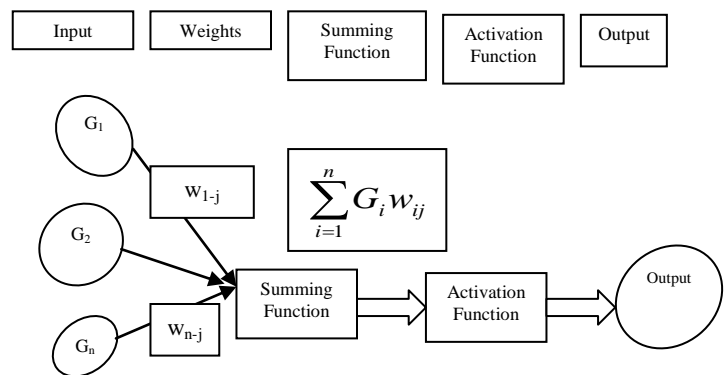

Figure 1. Elements of ANN

When a network has been structured for any problems, that network is ready to be trained. To start this process the initial weights are chosen randomly. Then, the training begins. There are two approaches to training, supervised and unsupervised training. Supervised training involves the governing outputs and the desired outputs to determine of performance of ANN (Figure 2). Unsupervised training is where the network has to make sense of the inputs without outside help [2].

Now, the goal of the training process is to obtain a desired output when the inputs are given. Since the error is the difference between the actual and the desired output, the error depends on the weights. The weights are adjusted in order to minimize the error. The error function can be defined for the output of each neuron:

$$E = \frac{1}{2} \sum E_m^2 \quad (3)$$

Where $E_m = (\text{Desired Outputs}) - (\text{Providing Outputs})$

The adjustment of each weight

$$\Delta A_{jm}^a(t) = \lambda \delta_m R_j^a + \alpha \Delta A_{jm}^a(t-1) \quad (4)$$

Where λ : learning rate, α : Momentum factor and δ_m : error of m output unit.

After training, ANN is tested with other input and outputs not presented to ANN before. When the error the difference between the actual and the desired output is acceptable, ANN learns the presented problem.

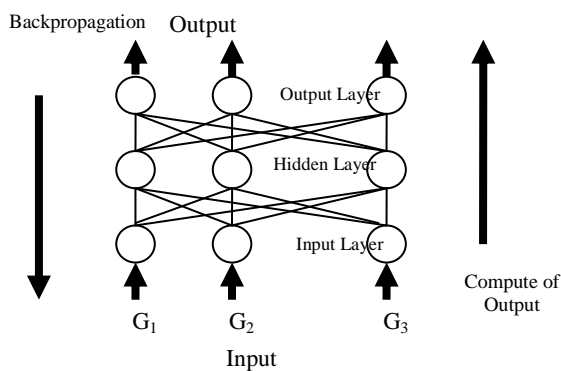

Figure 2. Topology of ANN

III. Results and Discussions

A. Experimental Results

The mortars produced are subjected to abrasion via the Bohme apparatus. Abrasion depths of the sample curing are determined after 7, 28, 90, 180, 270 and 360 days (Table 2). The minimum abrasion depth (<4.0 mm) occurs in CIV/A and CEM IV/B samples at the end of the year (Table 2). The deepest abrasion (>5 mm) occurs in the samples from CV/A and CV/B samples (Table 2). Thus, it can be said that the content of the pozzolanic material is restricted to about 25%-30%. If these materials are added to the cement more than this ratio, abrasion resistant is negatively influenced.

If abrasion depths of all the samples, without considering their composition, are determined, it is seen that the abrasion depth is shortened by extending the curing time. This means abrasion resistance increases. The samples are projected to reach ultimate abrasion depth in 6-9 months. This means the abrasion resistances of the samples improve more slowly after 6-9 months.

TABLE II. EXPERIMENTAL ABRASION DEPTH RESULTS (MM)

	7 Days	28 Days	90 Days	180 Days	270 Days	360 Days
CEM I	7.7	6.12	5.2	4.66	4.56	4.15
CEM II/A-M	10.5	9.12	6.1	4.16	4	3.91
CEM II/B-M	9.26	7.47	5.6	4.89	3.98	3.96
CEM IV/A	7.8	5.51	4.3	3.76	3.16	3.14
CEM IV/B	11.1	8.76	6.75	5	4.01	3.6
CEM V/A	11.25	9.53	7.4	6.52	5.38	5.3
CEM V/B	9.9	9.17	6.9	5.1	5.26	5.3

B. Numerical Results

In this study, abrasion depths of cement mortars having different pozzolanic composition are obtained using artificial neural network (ANN). While modeling of ANN, the backpropagation algorithm and supervised learning rule are used. 28 and 12 samples are used for training and testing sets, respectively (Table 3). In ANN model, one input layer (7 neurons), one hidden layer (1000 neurons) and one output layer (one neuron) are used. Input layer consists of pozzolanic compositions (CI, BFS, SF, NP, FA, LS (weight %)) and curing time (days). Output layer consists of abrasion depths of the mortar samples. The error tolerance is considered as 3%. When the require process is completed, ANN begins learn from provided data (28 samples). Training is finished when the error tolerance is less than 3%. Then, testing of ANN is begun from 14 samples not presented to ANN before. It is seen that most of the results in test set are less than the error 3% considered, therefore, it can be said that the results of ANN are good agreement with experimental results.

TABLE III. TESTING SET OF ANN

CI, wt%	BFS, wt%	SF, wt%	NP, wt%	FA, wt%	LS, wt%	Days	Abrasion mm (exp.)	Abrasion, mm, ANN	Error, %
100	0	0	0	0	0	28	6.12	6.51	6.31
85	3	3	3	3	3	90	6.1	5.22	14.36
85	3	3	3	3	3	7	10.5	10.68	1.68
75	5	5	5	5	5	360	3.96	3.94	0.55
75	5	5	5	5	5	180	4.89	4.84	1.04
70	0	5	15	10	0	180	3.76	2.43	35.41
55	0	5	20	20	0	28	8.76	10.15	15.91
55	0	5	20	20	0	90	6.75	6.72	0.48
45	20	0	20	15	0	7	11.25	10.10	10.19
45	20	0	20	15	0	360	5.3	3.91	26.28
35	40	0	15	10	0	270	5.26	5.42	2.97
35	40	0	15	10	0	28	9.17	9.43	2.88

IV. Conclusions

In this study, it is aimed to investigate the relationship between abrasion resistances and cement compositions by using standard test methods together with predictions of

Artificial Neural Networks (ANN). While modeling of ANN, the backpropagation algorithm and supervised learning rule are used. 28 and 12 samples are used for training and testing sets, respectively. The error tolerance is considered as 3%. The results obtained can be categorized as follows:

As experimental results, the content of the pozzolanic material is restricted to about 25%-30%. If these materials are added to the cement more than this ratio, abrasion resistant is negatively influenced. In addition, the abrasion resistances of the samples improve more slowly after 6-9 months.

Numerical results show that most of the results in test set are less than the error 3% considered, the results of ANN are good agreement with experimental results. Additionally, a few results are great than the error 3%. ANN solves the problem in a short time after training and testing of the network in comparison with experimental methods. Altering topology of ANN, new problems can be solved with small efficient energy.

References

- [1] Albayrak, S. And Uzman, Ü. (2006). Computing of moment and deflection of beam-columns using artificial neural networks, 7th International Congress on Advances in Civil Engineering, 11-13 October 2006 Yildiz Technical University, Istanbul, Turkey.
- [2] Anderson, D. and McNeill, G. (1992). Artificial neural networks technology, Kaman Sciences Corporation, New York.
- [3] ACI 201.2R, Guide to Durable Concrete, American Concrete Institute, USA, 1992.
- [4] Çavdar, A. and Yetgin Ş. (2010). Investigation of abrasion resistance of cement mortar with different pozzolanic compositions and subjected to sulfated medium, Construction and Building Materials, Volume 24, Issue 4, April, 461-470.
- [5] Shi ZQ and Chung DDL, (1997). Improving the abrasion resistance of mortar by adding latex and carbon fibers, Cement and Concrete Research. 27-8, 1149-1153.
- [6] Papenfus NJ, Abrasion Wear, Abrasion Resistance and Related Strength Characteristics in Concrete, with Special Reference to Concrete Pavers, PhD Thesis, Witwatersrand University, South Africa, 2002.
- [7] Yazıcı Ş and İnan G. (2006). An investigation on the wear resistance of high strength concretes, Wear. 260-6, 615-618
- [8] Ghafoori, N. and Diawara, H. (2007), Strength and wear resistance of sand-replaced silica fume concrete, ACI Materials Journal. 104-2, 206-214.
- [9] Li H, Zhang M and Ou J. (2006). Abrasion resistance of concrete containing nano-particles for pavement, Wear, 260-11, 1262-1266.
- [10] Gershenson, C. (2010), Artificial neural networks for beginners. [Online] Available from: <http://homepages.vub.ac.be/~cgershen/cogs/doc/FCS-ANN-tutorial.htm> [Accessed 19 February 2010].

About Authors:



Dr. Ahmet Çavdar was born in Trabzon, Turkey, in 1980. He received his B.D, M.S. and PhD degrees at Civil Engineering at Karadeniz Technical University, Turkey, in 2001, 2004 and 2008, respectively. He is an Assoc. Prof. Dr. at the Department of Civil Engineering, Gumushane University. His research interests include structural materials, durability of concrete and fibre-reinforced concrete.



Dr. Selahattin ALBAYRAK was born in Gümüşhane, Turkey, in 1981. He received his B.D, M.S. and PhD degrees at Civil Engineering at Karadeniz Technical University, Turkey, in 2001, 2005 and 2011, respectively. He is an Asst. Prof. Dr. at the Department of Civil Engineering, Gumushane University. His research interests include artificial neural networks, thin walled beams, lateral buckling and strength of materials.



Dr. Şükrü Yetgin was born in Malatya, Turkey, in 1953. He received his B.D and M.S. degrees in Universitaet GHS Essen, Germany, in 1983 and PhD degree at Universitaet Hannover, in 1995. He is an Assoc. Prof. Dr. at the Department of Civil Engineering, Gumushane University. His research interests include structural materials, durability of concrete and adobes.