

# ANALYSIS OF OR THOGONAL FREQUENCY DIVISION MULTIPLEXING (OFDM) SCHEME FOR MOBILE RADIO CHANNEL

<sup>1</sup>Nikhil Arora

*Roorkee Institute of  
Technology,  
Roorkee, UK, India*

<sup>2</sup>Ravish Kumar

*Roorkee Institute of  
Technology,  
Roorkee,UK, India*

<sup>3</sup>Anand Prakash

*Roorkee Institute of  
Technology,  
Roorkee,UK, India*

<sup>4</sup>Vishal Sharma

*Roorkee Institute of  
Technology,  
Roorkee, UK, India*

## Abstract

Orthogonal Frequency Division Multiplexing (OFDM) is a transmission technique which ensures efficient utilization of the spectrum by allowing overlap of carriers. OFDM is a combination of modulation and multiplexing that is used in the transmission of information and data. Compared with the other wireless transmission techniques like Frequency Division Multiple Access (FDMA), Code Division Multiple Access (CDMA), OFDM has numerous advantages like high spectral density, its robustness to channel fading, its ability to overcome several radio impairment factors such as effect of AWGN, impulse noise, multipath fading, etc. Due to this it finds wide application in Digital Audio Broadcasting (DAB), Digital Video Broadcasting (DVB), and Wireless LAN.

Most of the wireless LAN standards like IEEE 802.11a or IEEE 802.11g use the OFDM as the main multiplexing scheme for better use of spectrum. In fact in the 4G telecommunication system OFDMA is the backbone of it.

This paper deals with the software simulation of this OFDM system in a mobile radio channel using the software tools of MATLAB®. From this simulation the performance of OFDM system in mobile radio channel is studied.

## Keywords

Multicarrier modulation, FFT, IFFT, Frequency selective fading, Cyclic prefix, OFDM.

## [I].Introduction

With the advance of communications technology comes the demand for higher data rate services such as multimedia, voice, and data over both wired and wireless links. New modulation schemes are required to transfer the large amounts of data which existing 3rd generation schemes such as Global System Mobile (GSM), its enhanced version Enhanced Data Rates for Global Evolution (EDGE), and Wideband Code Division Multiple Access (WCDMA) cannot support. These new modulation schemes must be able to act over point to point links and in broadcast mode, support bi-directional communications, and be able to adapt to

different requirements of individual services in terms of their data rate, allowable Bit Error Rate (BER), and maximum delay.

One new modulation scheme which has received significant attention over the last few years is a form of multicarrier modulation called Orthogonal Frequency Division Multiplexing (OFDM). OFDM has been used for Digital Audio Broadcasting (DAB) and Digital Video Broadcasting (DVB) in Europe and for Asymmetric Digital Subscriber Line (ADSL) high data rate wired links. OFDM has also been standardized as the physical layer for the

wireless networking standard 'HIPERLAN2' in Europe and as the IEEE 802.11a, g standard in the US, promising raw data rates of between 6 and 54Mbps. OFDM has various properties that make it desirable over existing single carrier systems, the main advantage is OFDM's immunity to frequency selective fading [1].

We are all interested in the future, for that is where you and I are going to spend the rest of our lives. And remember my friend; future events such as these will affect you in the future." Single carrier systems can increase their data rate by shortening the symbol time, thereby increasing the occupied bandwidth. Wideband channels are sensitive to frequency selective fading which require complex equalizers in the receiver to recover the original signal. OFDM overcomes this problem by dividing the wideband channel into a series of narrowband channels which each experience flat fading.

Therefore only 1 tap equalizers are required in the receiver, reducing complexity greatly. Other factors such as advances in silicon and Digital Signal Processing (DSP) allow the use of efficient Fourier transforms in the transmitter and receiver to perform the modulation, demodulation respectively. Due to the orthogonality of the subcarriers the transmission bandwidth is used efficiently as the subcarriers are allowed to overlap each other and still be decoded at the receiver. Despite the many advantages of OFDM it still suffers from some limitations such as sensitivity to carrier frequency offset and a large Peak to Average

Power Ratio (PAPR). The large PAPR is due to the superposition of independent equally spaced subcarriers at the output of the Inverse Fast Fourier Transform (IFFT) in the transmitter. A large PAPR is a problem as it requires increased complexity in the word length at the output of the IFFT and the Digital to Analog Converter (DAC) [2].

Perhaps the most serious problem is the reduced efficiency of the High Power Amplifier (HPA) which must cater for these low probabilities large peaks. If the high PAPR is allowed to saturate the HPA out of band radiation is produced affecting adjacent channels and degrading the BER at the receiver. As portable devices have a finite battery life it is important to find ways of reducing the PAPR allowing for a smaller more efficient HPA, which in turn will mean a longer lasting battery life.

A scheme of every part of the implementation can be seen in Fig 1.1. As it can be seen in the figure channel imperfections are modeled in this implementation. In the end of the transmission, when the receiver receives the data, a comparison of the transmitted and the received messages is done in order to calculate the Bit Error Ratio (BER). This paper does not explain in detail the simulation code. It uses it to create results and see the behavior of OFDM under different channel properties. Nevertheless some of the main variables of the code are described, because the choice of them has a critical effect on the results.

## [II]. Multicarrier Principal

An early form of a multicarrier system is shown in Figure 1.1. The basic principle of multicarrier modulation is to divide the data stream,  $d$ , into  $N$  parallel data streams with a reduced data rate of  $d/N$ . Each low rate data stream is then modulated on a separate narrow band subcarrier and summed together for transmission, thereby providing the same data rate as an equivalent single carrier system. At the receiver a set of

filter banks separate the wideband signal into the original narrowband subcarriers for demodulation. The advantage of this structure over single carrier systems is that the extended symbol time (due to lower data rate) makes the signal less susceptible to effects of the channel such as multipath propagation which introduces Inter Symbol Interference (ISI). Each sub channel will therefore experience flat fading

reducing the equalization complexity in the receiver dramatically.

This issue will be explored in more depth in .A disadvantage of the method shown in Figure 1.1 is the implementation complexity due to the large number of filter banks required in the transmitter and receiver as well as the inefficient use of the available frequency band. The spectra of the different carriers cannot overlap as this

would introduce distortion degrading system performance [3].

A more spectrally efficient implementation of the aforementioned multicarrier system is OFDM (Figure 1.2). In OFDM the transmit signals are constructed in such a way that the frequency spectra of the individual sub channels are allowed to overlap thereby utilizing the frequency spectrum much more efficiently.

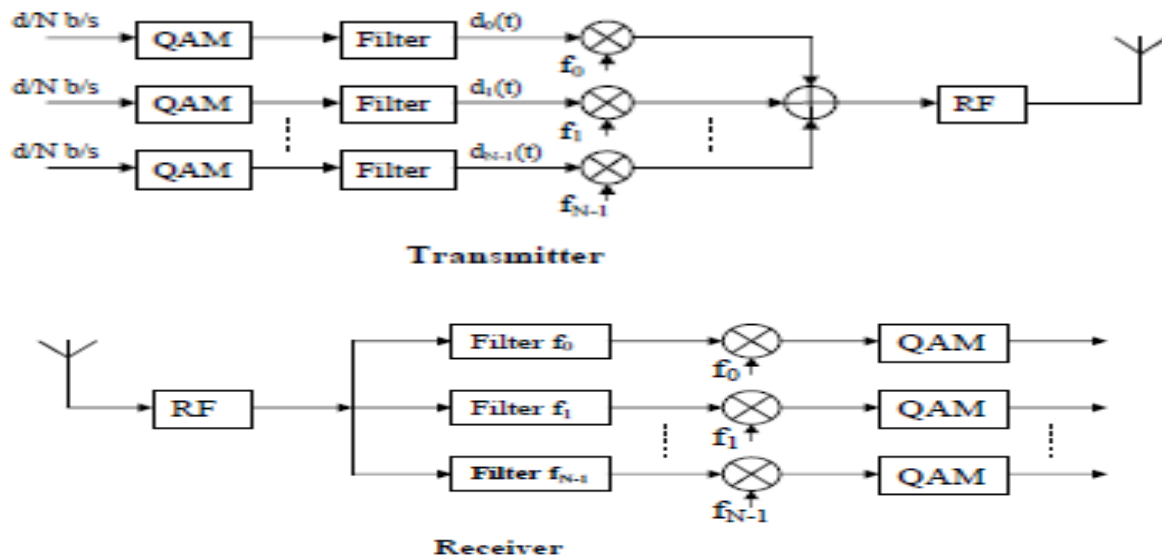

Figure 1.1:-Basic Transmitter and Receiver

[III].Use of FFT and Inverse Fourier transform

In order to make multicarrier systems a more practical technology an IDFT and DFT are used for the baseband modulation and demodulation respectively, as first suggested in reference where the sinusoidal nature of the Fourier transform basic functions is exploited. Advances in silicon technology have made the production of the DFT more cost efficient. Figure 1.2 shows a block diagram of a basic OFDM system in the baseband utilizing the IDFT, DFT pair. A discrete time representation of can be obtained by sampling the continuous signal. Under the condition that the signal can be determined by

its samples if sampled at  $T=tN$  under this condition [5].

$$x(n) = \frac{1}{\sqrt{N}} \sum_{k=0}^{N-1} X(k) e^{j2\pi kn/N}, \quad 0 \leq n \leq N-1$$

Where ‘n’ are the discrete sampling points. This equation describes exactly the IDFT operation. In hardware the more efficient form of the IDFT and DFT, the Inverse Fast Fourier Transform (IFFT) and Fast Fourier Transform (FFT) is used for the modulation, demodulation respectively, where N is set to be a power of 2. Figure 1.2 shows a baseband transceiver structure for OFDM utilizing the Fourier transform for modulation and demodulation.. The data is then demultiplexed by a serial to

parallel converter resulting in a block of  $N$  complex symbols,  $X(0)$  to  $X(N-1)$ . The parallel samples are then passed through an  $N$  point IFFT (in this case no oversampling is assumed) with a rectangular window of length  $NT_s$ , resulting in complex samples  $x(0)$  to  $x(N-1)$ . Assuming the incoming complex data is random it follows that the IFFT is a set of independent random complex sinusoidal assumed together. The samples,  $x(0)$  to  $x(N-1)$  are then converted back into a serial data stream producing a baseband OFDM transmit symbol of length  $T=N.T_s$  [4].

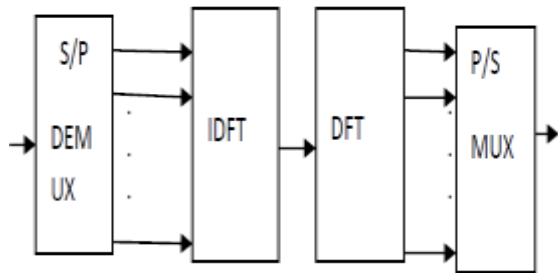

Figure 1.2:-Block diagram of OFDM

#### [IV].Simulation Results

The simulation work is done with the help of Matlab. The figure 1.2 is simulated by using the modulation technique like QAM having the no. of sub carriers ( $N$ ) = 64 and no. of bits =256. The following table shows the modulation technique used through which we can analyse the OFDM System. QAM is used as a modulation technique due to the band-width

#### [V].Future Work

The PAPR problem in OFDM is still an ongoing issue, especially for portable devices where the need to minimize the power amplifier linear range is paramount. The PTS/CSS/TI methods developed to reduce the PAPR can be combined with other PTS techniques such as adaptive PTS and variations of the blind SLM techniques to further reduce complexity and the peak power.

conservation as the expense of increased power with FFT and IFFT algorithm.

No. of bits (k)	Modulation technique	NO. of sub-carriers N	Carrier Frequency
256	4-ary QAM	64	20MHz

In figure 1.3, OFDM system in figure 1.1 is simulated by the matlab. The blue part of the graph shows a OFDM transmitted signal and the red part shows the OFDM received signal with the noise. The channel is taken to be a AWGN channel having a noise power spectral density flat.

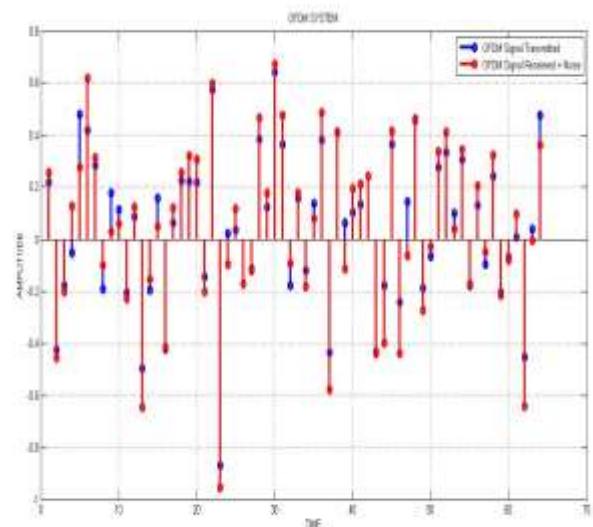

Figure 1.3:- Simulation of OFDM System

A hybrid system utilizing clipping techniques could also be added as a last stage so as to have an upper bound for the PTS signal. Analysis of the proposed algorithms in a MIMO OFDM system is an area that has gained a lot of focus recently and analysis of the performance of the proposed techniques in such an environment would be valid.

[VI].References

- [1] Wayne Tomasi, Advanced Electronic Communication Systems, 6th edition, Pearson Education.
- [2] T. S. Rappaport, Wireless Communications, Principles and Practice. New Jersey: Prentice Hall, 1996.
- [3] S. H. Mller, R. W. Buml, R. F. H. Fischer, and J. B. Huber,“OFDM with Reduced Peak-to-Average Power Ratio by Multiple Signal Representation,” Annals of Telecommun., vol. 52,no. 12, pp. 5867, Feb. 1997.
- [4] L. J. Cimini Jr, Ye, L,“ Orthogonal Frequency Division Multiplexing forWireless Channels,”inIEEEGlobalTelecommunications Conference GLOBECOM, Sydney, Australia, 1998, p.82.
- [5] Y. Jung, Y. Tak, J. Kim, J. Park, D. Kim, and H. Park,“ Efficient FFT algorithm for OFDMmodulation,” in Electrical and Electronic Technology, 2001. TENCON. Proceedings of IEEE region 10 International Conference on, 2001, pp. 676-678 vol.2.