

SERVICE RESTORATION USING GENETIC ALGORITHM AND EXPERT SYSTEM

Arthit Srikaew

School of Electrical Engineering
Institute of Engineering , Suranaree University of
Technology
Nakhonratchasima, Thailand
ra@sut.ac.th

Nattaphan Teerawatwittaya

School of Electrical Engineering
Institute of Engineering , Suranaree University of
Technology
Nakhonratchasima, Thailand
nattaphan.t@hotmail.com

Abstract - This paper develops a hybrid system for solving a service restoration problem in a distribution system using genetic algorithm (GA) and expert systems (ES). The main objective in problem of finding the optimal state of a sectionalizing switch on faults occurred is to restore as many loads as possible by transferring de-energized loads via network reconfigurations to other supporting distribution feeder without violating operating and engineering constraints. The Expert System to collect data from users. For analysis and the variables that are associated with the processing. And Genetic algorithm will process the results from an expert system modules. The feasibility of the developed algorithm for service restoration is demonstrated on distribution network with promising result.

Keywords— Power flow, Genetic algorithm, Expert system, Service restoration, Hybrid system

I. INTRODUCTION

Customer satisfaction and service reliability are of primary concern in power industry. Several studies on power utility experience suggest that customer satisfaction is more closely correlated with service interruption frequency and interruption duration. Developing effective service restoration procedures is a cost-effective approach to improve service reliability and consequently, enhance customer satisfaction.

The main objective in service restoration procedures is to restore as many loads as possible (i.e. minimize loads in out-of-service areas) by transferring de-energized loads in out of service areas via network reconfiguration to other supporting distribution feeders without violating operating and engineering constraints. Fast service restoration has multi-fold benefit. In actual use, distribution operators need to restore service to out-of-service areas as quickly as possible. Currently, the restoration is performed step-by-step and mostly manually, based on pre-established guidelines and operating procedures.

The service restoration problem is a combinatorial, non-linear, and constrained optimization problem. The

complexity of such a problem calls into doubts the effectiveness of the restoration procedures based on pre-established guidelines. In fact, the service restoration problem belongs to the so-called NP-complete problem. There are no known methods to solve NP-complete problems exactly in a reasonable time.

In the past, considerable efforts have been devoted to the subject of service restoration in electric power distribution systems. The approaches [1-4] are base on application of various optimization methods to determine the optimal restoration plan of the electric power distribution systems. The shortcoming of these methods is that, the nature of the problem is so complex and due to the burdening of performance variants and due to practical difficulties, the desired optimal solution cannot be obtained in the minimum possible time. The increased computational time with large size distribution system limit the efficient use of these approaches in service restoration procedures of distribution automation system.

The heuristic approaches [5-7] are base on the idea of the network configuration, multiple alternative supply sources, and protection facilities of the distribution system. The main drawback of these approaches is that the distribution system facility under normal operating condition will not match with the same under abnormal condition. Hence these heuristic approaches fail to obtain an optimal solution for the constrained electrical power service restoration problem.

The expert system based approach [8], need complete knowledge of electrical power distribution system for determining its optimal restoration plan. However, the system dependency of this expert system approach makes is not a suitable general technique to solve electrical power service restoration problem.

This paper is outlined in 7 parts. In Section 2 of the paper details the description of service restoration using Expert System. In Section 3 of the paper details the description of service restoration using Genetic Algorithm. In Section 4, overall solution algorithm of the hybrid system for service restoration using Expert System and Genetic Algorithm. In Section 5 gives the test data, results and its analysis. Conclusion is presented in Section 6 of the paper. List of conferences is given in the last part of the paper.

II. SERVICE RESTORATION USING EXPERT SYSTEM

Expert Systems (ES) is a computer program that can be expressed as experts in their fields or for specific use. Or refers to the software systems, which are similar in terms of the reasoning process and provide information about the people who have to decide. It is found in the human experts. Expert systems are an important element in element 5, with details as follows :

- Knowledge base contains information specific to the knowledge that is used to solve the problem of the expert system. Knowledge is in the form of IF-THEN rules.
- Database contains a set of facts. Used for checking the conditions in a rule IF, in the knowledge base.
- Inference engine is part of the reason for the complex calculations lead to answers. Served in the rules of the knowledge base. Facts from the database.
- Explanation facility that allows a user to understand the answer anyway. And the fact that I need. Expert system must be able to explain the behavior of the system. And provide guidance. Analysis or conclusion.
- A response to the user (User interface) is the interaction between the user and the expert system. Retaliation should be efficient and easy to use as possible.

As mentioned in the above. Expert system to collect data from users for analysis and the variables (sectionalizing and tie switches.) that are associated with the processing. Analysis and the variables are not related. Can be achieved through the rule base of an expert system. The rule base of an expert system that determines the variable to be processed. The details are as follows.

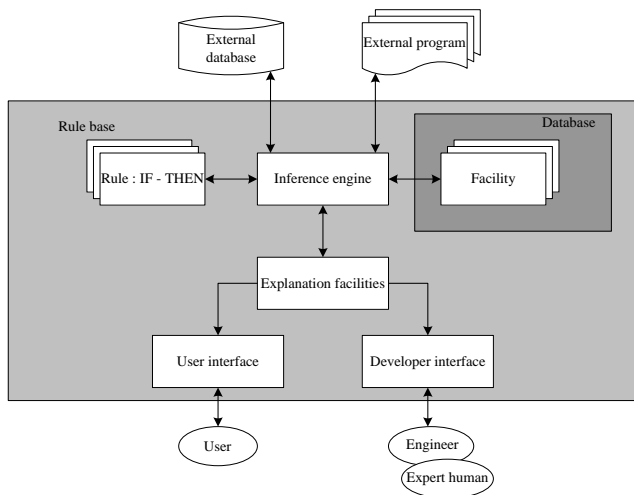

Fig. 1 Structure of expert system

RULE

- IF: [Fault locate is not at end of feeder]
 And [Bus transfer is not fault]
 And [Main bus is not fault]

- And [Main bus can increase load form feeder fault]
 And [User or operator is want to restoration]
 THEN:
 [Defined number of variables to the GA process.]

III. SERVICE RESTORATION USING GENETIC ALGORITHM

Genetic Algorithm is a method that mimics the process of natural evolution. This genetic algorithm is a mathematical solution to a stochastic algorithm is used to find the global optimal solution of the objective function. Genetic algorithm is presented for the first time publicly by John Holland in the year, 1975. The answer to the evolutionary theory of Charles Darwin described a strong than they were able to survive. And broadcast feature with the next generation. Therefore, the process or the operator in such a way is called the genetic biology. such as selection is the process to select populations with the strength of the population. Crossover is the process to create population with features from the parents. And mutation, this process will continue within the population genetic diversity. The genetic approach is successfully applied to find the optimal solution. In many fields, including the electrical power system. Issues such as the selection of power with regard to economics, the problem of optimal control, the planning system. The problem of finding the appropriate other, etc.

As mentioned in the above. When the faults in the distribution system. The important thing to consider first is to reduce power during fault in the distribution system to a minimum. Therefore to find out the status of the sectionalizing switch, suitable, it is especially important. Due to the state of the switch may extracted improperly causing a power outage in the area do not want a power outage. Power failure or a problem has a wide area. The genetic algorithm is an appropriate method for determining the status of the sectionalizing switch to the appropriate citation. Because the method of genetic algorithm can change condition and objectives easily. The objective function of the genetic method combines objective and reasonable criteria for finding the response of the state of the sectionalizing switch for the appropriate citation.

The genetic algorithm starts with number of solutions to a problem, encoded as a string of status of sectionalizing and tie switches. The status of the switch '1' and '0' has been considered as 'close' and 'open' condition of the switch. The string that encodes each string is 'chromosome' and the set of solutions are termed as population. The following modifications are done in the implementation of GA to solve the Electric Power Service Restoration Problem.

- Length of the Chromosome = Number of Buses in EPDS
 Population size = Total number of sectionalizing and tie switches in the EPDS (i.e. nbch)

Probability of crossover
 $P_C = 0.7$ (1)

Probability of mutation
 $P_m = P_C / nbch$ (2)

nbch number branch of distribution system

IV. SERVICE RESTORATION USING HYBRID SYSTEM

The solution to the service restoration optimization problem should meet the following requirements:

- The Power Loss in the reconfigured distribution system should be as less as possible.
- Radial Structure of the distribution system should be retained.
- Overloading of the Transformers and Feeders should be minimum.
- The switch operations should be as less as possible in order to minimize the interruption of power supply.
- The Power supply should be restored to as much load as possible in the minimum time and the load shedding should be according to the highest priority order consideration of the loads.
- The Restoration time should be minimum.

The multi-objective function for solving the Electric Power Service Restoration Problem is formulated as follows:

Minimize $F = w_1f_1 + w_2f_2 + w_3f_3 + w_4f_4 + w_5f_5 + w_6f_6$ (3)

Subject to the following constraints

(1) Constraint on bus voltages
 $V_{k \min} \leq V_k \leq V_{k \max}$ (4)

(2) Constraint on Real Power Transmission Loss
 $PLL \leq PLL_{\max}$ (5)

(3) Constraint on number of switch operations
 $SWOP \cong 0$ (6)

(4) Constraint on overloading of transformer
 $TFL \leq TFL_{\max}$ (7)

(5) Constraints on feeder overloading
 $FDL \leq FDL_{\max}$ (8)

(6) Constraint on priority order consideration of loads
 $SMLP = \sum_{i=1}^{nload} LPRO_i$ (9)

i.e.; $w_1 = w_2 = w_3 = w_4 = w_5 = w_6 = 1$

Service restoration in distribution system will contain considered at the least time, to simplify the analysis of the state of the sectionalizing switch to the appropriate citation in the distribution system. And mathematical calculations accurately. The process works as follows.

Step 1 : Read the Bus Data, LPRO's, Real and Reactive Power Demand, Shunt Capacitor Bank Ratings.

Read the Line Data, the number of feeders & the bus number at which substation/source is connected and Read the convergence tolerance.

Step 2 : Locate the faulted system or in the location where you want to open the circuit.

Step 3 : Expert System module to collect data from users. For analysis and the variables that are associated with the processing.

Step 4 : Genetic algorithm module will process the results from an expert system modules. When processing is completed, the process will result in the display monitor.

From the work in process above. Can write brief work plan: Figure 2

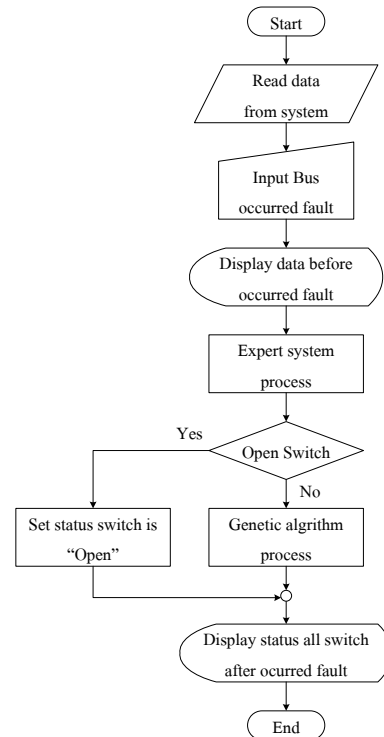

Fig. 2 Flow chart of ES-GA Method

V. CASE STUDY

A. Result and discussion for 16-Bus practical distribution system

In this section, we show an experimental result of applying the proposed method to the testing system shown in Fig. 3. The system has 3 feeders 13 loads 16 bus and 16 switch. Through SW1, SW2, SW3, SW4, SW5, SW6, SW7, SW8, SW10, SW11, SW12, SW14 and SW15 are closed circuit and SW9, SW13 and SW16 are open circuit.

The status information of a switch in the excerpt above, can be arranged in a matrix of a genetic chromosome. By the switch to open the circuit in the state has a value of "0" and the switch is in a closed circuit with a value of "1" is as follows.

SWSTAT = [1 1 1 1 1 1 1 1 0 1 1 1 0 1 1 0]

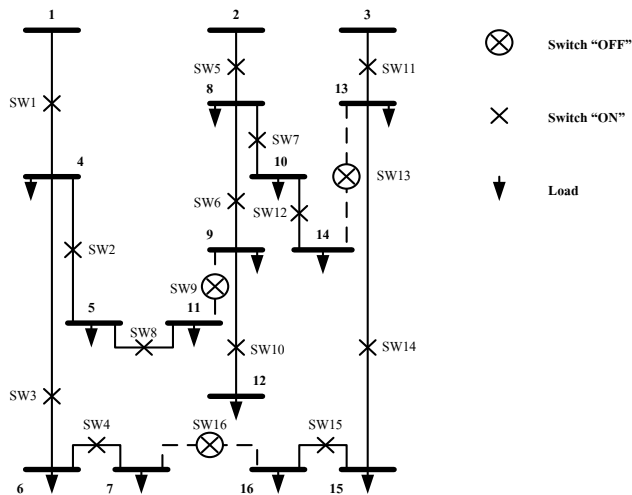

Fig. 3 System 16 bus before occurred fault

B. Result and discussion for 16-Bus practical distribution system

In this section, we show an experimental result of applying the proposed method to the testing system shown in Fig. 3. The system has 3 feeders 13 loads 16 bus and 16 switch. Through SW1, SW2, SW3, SW4, SW5, SW6, SW7, SW8, SW10, SW11, SW12, SW14 and SW15 are closed circuit and SW9, SW13 and SW16 are open circuit.

The status information of a switch in the excerpt above, can be arranged in a matrix of a genetic chromosome. By the switch to open the circuit in the state has a value of "0" and the switch is in a closed circuit with a value of "1" is as follows.

$$SWSTAT = [1 \ 1 \ 1 \ 1 \ 1 \ 1 \ 1 \ 1 \ 0 \ 1 \ 1 \ 1 \ 0 \ 1 \ 1 \ 0]$$

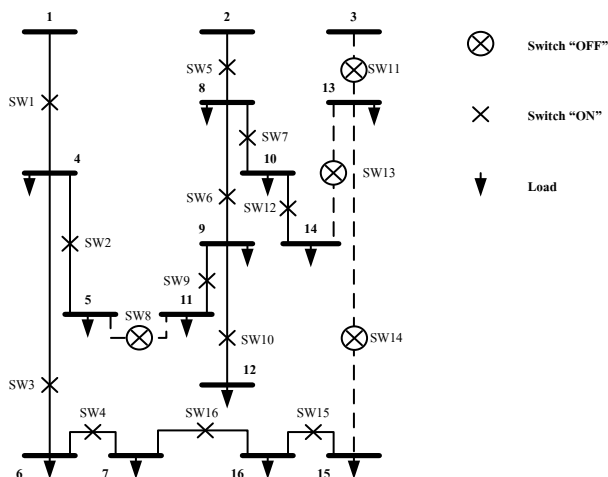

Fig. 4 System 16 bus post occurred fault

Table I
Comparisons of two strategy of system 16 bus

Strategy	Time (sec)
Genetic Algorithm	9.1835
Expert System and Genetic Algorithm	3.8349

C. Result and discussion for 100-Bus practical distribution system

The system has 5 feeders 100 loads 100 bus and 106 switch. Through SW1, SW2, SW3, SW4, SW5 is a tie switch are open circuit and another switch are closed circuit is shown in Fig. 5. The results of running the test system, is shown Fig. 6.

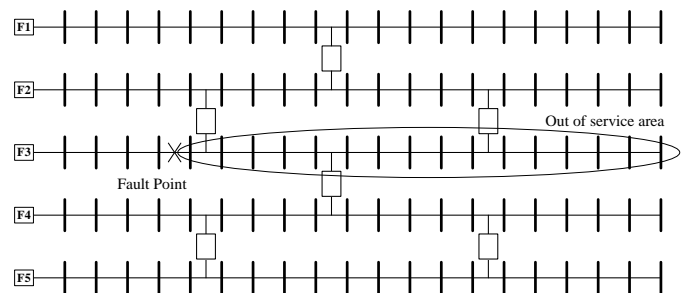

Fig. 5 System 100 bus before occurred fault

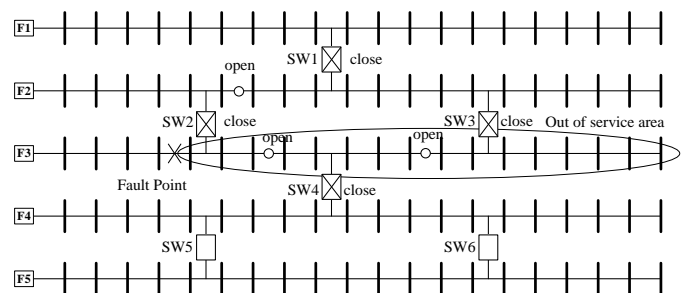

Fig. 6 System 100 bus post occurred fault

Table II
Comparisons of two strategy of system 100 bus

Strategy	Time (sec)
Genetic Algorithm	135.1005
Expert System and Genetic Algorithm	56.4464

VI. CONCLUSION

Service restoration using genetic algorithm and expert system is one way to solve the problem of the sectionalize switch for the appropriate. As a technique that can improve the speed of finding an answer. But it is the only system with multiple feeder. The technique presented is a technique that uses an Expert System to assist in reducing the number of variables and the Genetic

Algorithm is used to find the optimum. If a system or test system has only one feeder that such techniques can not reduce the number of variables as much as it should.

REFERENCES

- [1] Sarma NDR, Ghosh S, Prakasa Rao KS, Srinivas N. Real time service restoration in distribution networks – a practical approach. *IEEE Trans Power Delivery* 1994;9(4):2064–70.
- [2] Ucak Canbolat, Pahwa Anil. An analytical approach for step by step restoration of distribution systems following extended outages. *IEEE Trans Power Delivery* 1994;9(3):952–8.
- [3] Sarma NDR, Prasad VC, Prakasa Rao KS, Sankar V. A new network reconfiguration technique for service restoration in distribution networks. *IEEE Trans Power Delivery* 1994;9(4):1936–42.
- [4] Shirmohammadi Dariush. Service restoration in distribution networks via network reconfiguration. *IEEE Trans Power Delivery* 1992;7(2):952–8.
- [5] Hsu Y-Y, Huang HM, Kuo HC, Peng SK, Chang CW, Chang KJ, et al. Distribution system service restoration using a heuristic search approach. *IEEE Trans Power Delivery* 1992;7(2).
- [6] Das JK, Chowdhury S, Chowdhury SP, Choudhuri S. Development of restoration algorithm for a typical power system to study post fault network topology. *IE(I) J. – EL* 2000;81(December):106–9.
- [7] Toune Sakae, Fudo Hiroyuki, Genji Takamu, Fukuyama Yoshikazu, Nakanishi Yosuke. Comparative study of modern heuristic algorithms to service restoration in distribution systems. *IEEE Trans Power Delivery* 2002;17(1):173–81.
- [8] Kafka RJ. System restoration plan development for a metropolitan electric system. *IEEE Trans Power Appar Syst* 1981;100:3703–13.
- [9] J.Inagaki, J.Nakamiya and M.Haseyama .: “A Multi-objective Service Restoration Method for Power Distribution System” *IEEE Trans. Power Deliv.* (2006) 1784 - 1787
- [10] K.Manjunath and M.R.Mohan.: “A New Hybrid Multi-Objective Quick Service Restoration technique for Electrical Power Distribution System” *Electrical Power and Energy System* 29 (2007) 51-64
- [11] Y.Kumar , B.Das and J.Sharma .: “Service restoration in distribution system using non-dominant sorting genetic algorithm” Department of Electrical Engineering. India Institute of Technology 2006
- [12] S. Srivastava, K.L. Butler-Burry. Expert-system method for automatic reconfiguration for restoration of shipboard power system. *IEE Proc.-Gener. Transm. Distrib.*, 2006