

# “DEVELOPMENT OF ENERGY HARVESTING SOURCE FROM PIEZOELECTRIC SHOE”

Ms.KambleSushamaBaburao

*Student M Tech (Electronics)*  
*Rajarambapu Institute of Technology,*  
*Rajaramnagar,Sakharale-415416*  
*Sush.06kamble@gmail.com*

## *Abstract*

Recent advances in energy harvesting have been intensified due to urgent need of portable, wireless electronics with extensive life span. The idea of energy harvesting is applicable to sensors that are placed and operated on some entities for a long time, or embedded into structures or human bodies, in which it is troublesome to replace the sensor module batteries. Such sensors are commonly called “self-powered sensors.”The idea of energy harvesting is applicable to sensors that are placed and operated on some entities for a long time, or embedded into structures or human bodies, in which it is troublesome or detrimental to replace the sensor module batteries. Such sensors are commonly called” self-powered sensors.”

The energy harvester devices are capable of capturing environmental energy and supplanting the battery in a stand-alone module, or working along with the battery to extend substantially its life. Vibration is considered one of the most high power and efficient among other ambient energy sources, such as a solar energy and temperature difference. Piezoelectric and electromagnetic devices are mostly used to convert vibration to ac electric power. For vibratory harvesting, a delicately-designed power conditioning circuit is required to store as much as possible of the device-output power into a battery. The design for this power conditioning needs to be consistent with the electric characteristics of the device and battery to achieve maximum power transfer and efficiency. This study offers an overview on various power conditioning electronic circuits designed for vibratory harvester devices and their applications to self powered sensors. Comparative comments are provided in terms of circuit topology differences, conversion efficiencies and applicability to a sensor.

**Keywords:** Energy harvesting, power generation, shoe power, dc/dc conversion.

## **I. Introduction**

Recently energy harvesting become more popular and one of the popular technique is generation of energy from surroundings. This technique is commonly called as Energy Harvesting. The energy harvesting source of

electrical energy can be used for autonomous feeding of remote applications ,electronics low power devices and wireless sensors. The energy harvesting devices generates electric energy using some energy conversion method .Therefore energy harvesting devices here considered do not consume any fuel or substance.

TABLE 1.1 ENVIRONMENTAL ENERGY SOURCES

Energy Harvesting Method	Power Density
Solar Cells- outdoors	15 mW/cm <sup>2</sup>
Piezoelectric shoes	330 μW/cm <sup>3</sup>
Vibration – microwave oven	116μ W/cm <sup>3</sup>
Thermoelectric (10°C gradient)	40 μW/cm <sup>3</sup>

The ambient energy is everywhere in the environment surrounding us .this energy is available in the form of radiation (solar or RF radiation),thermal energy and mechanical energy of the environment or energy of chemical or biological sources. In the nature the ambient energy can be suitable source of energy to powering of remote applications which are shown in table 1.1.The powered device is placed in environment with a suitable type of ambient energy with sufficient an energy density .if the amount of input energy density is in accordance with required output power ,then the energy harvesting device could be used as independent source of electrical energy for electronics The powered device is placed in environment with a suitable type of ambient energy with sufficient an energy density. If the amount of input energy density is in accordance with required output power, then the energy harvesting device could be used as independent source of electrical energy for electronics.

A schematic diagram of the generally energy harvesting system is shown in fig1.1.Power is regulated with a self-powered dc/dc conversion circuit that achieves a high 65% efficiency for converting the high piezoelectrically generated voltage (130 v) to a low

voltage (4 v) suitable for portable electronic devices. The entire power generation system is embedded into shoe heel, has large power output (4 mw raw power, 2.6mw regulated power per shoe) and is small, soft, lightweight, durable, and low cost.

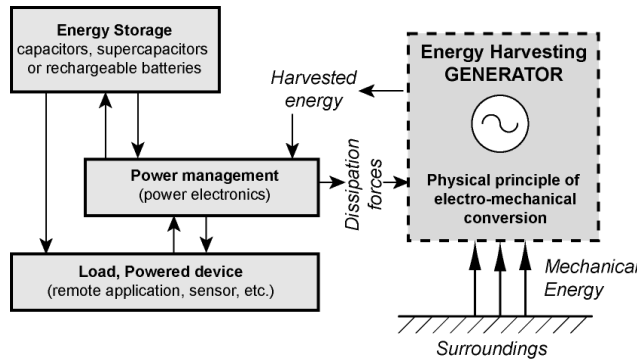

Fig.1.1 Schematic of Energy Harvesting System

Microstructured piezoelectric polymer film that is used for the power generation. The film thickness is approximately 80µm and it is filled with the microcells that have an average diameter of 30µm. Due to the microcell structure, the polymer has a low effective Young's modulus of 3-6 MPa and it can readily be integrated inside the shoe heel as a compact stack. The transducer total weight is 6.5gm which compares to the regular shoe filling [2]. Number of transducer can be cascaded to increase the output energy of the transducer.

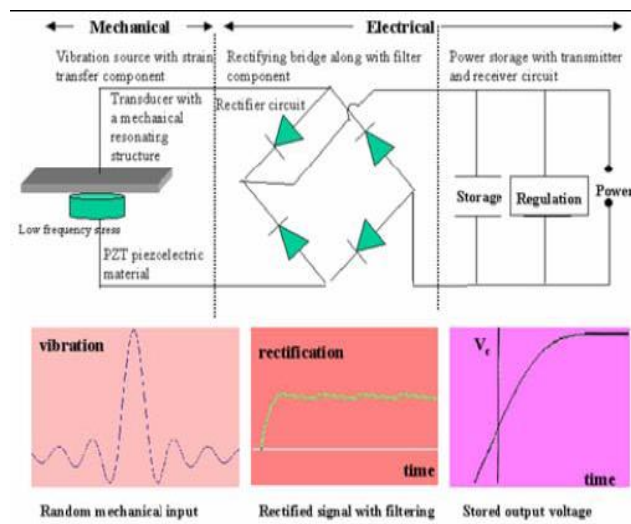

Fig1.2-Schematic representation of the piezoelectric harvesting energy process.

As shown in fig 1.2, this project studies the process variables affecting the generation of electric power from

mechanical vibrations in the form of environmental causes. Further this project investigates the infrastructure needed for mass scale energy production. Presently there is no commercial technology available for harnessing the available environmental energy at a mass scale. The project will be carried out as follows. The part of this project investigates the potential for piezoelectric-based energy harvesting system to achieve the following capabilities:

- i) Large power generation for charging the batteries of electronic components.
- ii) Large voltage regulation.
- iii) Signal generation for remote control.
- iv) Small voltage and power generation for sensing and monitor.

**II. System Block Diagram**

Fig 2.1 shows the system block diagram of generation of energy source by using piezoelectric shoes.

**Piezoelectric transducer**

There are all kind of situations where we need to convert mechanical energy (pressure or movement of some kind) into electrical signals or vice-versa. Often we can do that with a piezoelectric transducer. A transducer is simply a device that converts small amount of energy from one kind to another (for example converting light, sound, or mechanical pressure into electrical signals).

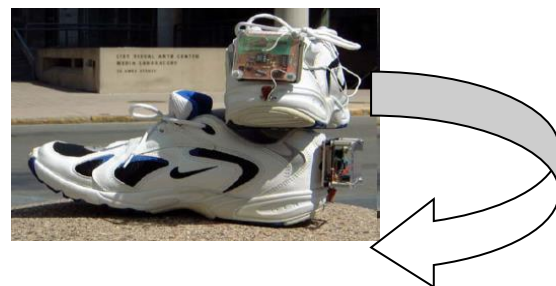

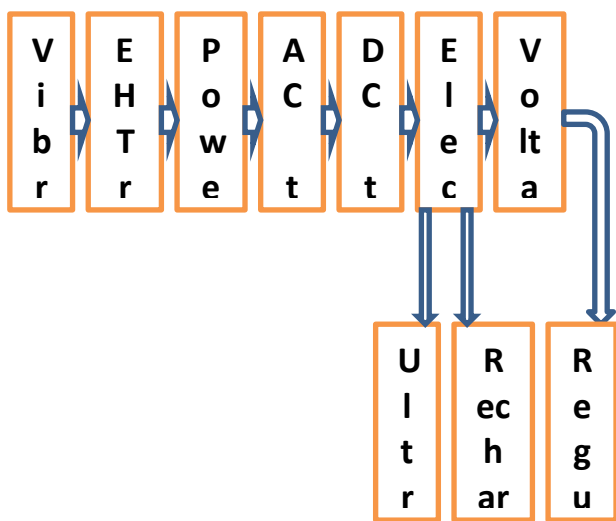

Fig.2.1 Proposed system Block Diagram

Piezoelectrically, is an effect that occurs when mechanical stress is applied to certain materials .An electrical polarization is set up in the crystal with the result that the faces become electrically charged. The charge reverses if the compression changes to tension. Because the effect is reversible an electric field applied across the material causes it to contract or expand ,according to the sign of the field. Piezoelectric material include; Quartz crystals, Rochelle salts, barium titanate

**The piezoelectric effect**

As shown in figure 2.2 the piezoelectric stress and an electrical voltage in solids .It is reversible: an applied effect describes the relation between a mechanical stress will generate a voltage and an applied voltage will change the shape of the solid by a small amount (up to a 4% change in volume).In physics the piezoelectric effect can be described as the link between electrostatics and mechanics.

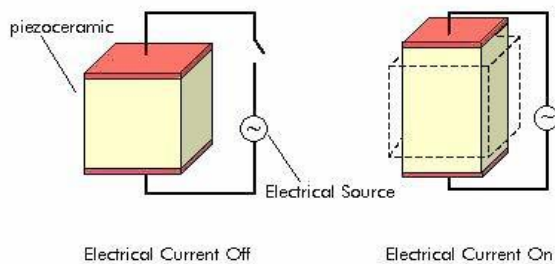

Fig 2.2 piezoelectric effect

**The Piezoelectric Materials**

The piezoelectric effect occurs only in nonconductive materials .Piezoelectric materials can be divided in 2 main groups: crystal and ceramics.

The most well known crystal piezoelectric material is quartz (SiO<sub>2</sub>), and the ceramic piezoelectric material is Lead ZirconateTitanate(PZT).PZT is be best piezoceramics,but the pure PZT usually is not perfect, by doping the piezoelectric material, its piezoelectric characteristics can be modified: especially the hardness or softness of the material, for example, doping the Sb<sub>2</sub>O<sub>3</sub>,Nb<sub>2</sub>O<sub>5</sub>,BaCO<sub>3</sub> and so on.

**The working method of the piezoelectric Acoustic Generator Element**

The basic element in all of these is a piezoelectric ceramic mounted on a metal diaphragm. When AC voltage is applied across theelectrodes of the piezoelectric ceramicits expands and contracts at the frequency applied. This causes the metal diaphragm bend ,producing sound waves (figure 2.3).The metal diaphragm is usually brass, stainless steel or nickel alloy. Thickness less than 0.5 mm.PZT ceramic material is used as the piezoelectric element. This element is designed so that the mechanical resonant frequency matches the frequency of the driving signal.

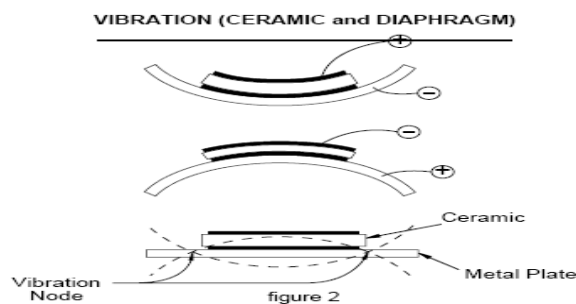

Fig 2.3vibration (ceramic &diaphragm)

**Available Piezoelectric Generator types**

1. two terminal circle type
2. three terminal circle with brim feedback
3. three terminal circle with centre feedback
4. two terminal square type

**Selection andTesting of piezoelectric transducer characteristics**

We can select the piezoelectric transducer on the following bases

- Free from RF noise and contact sparking
- Simple compact and light weight
- Consume little power and have long life
- Generate various timbers of pitches.

To generate voltage at the output of .we can apply the mechanical stress to single sheet of piezoceramic in two way:

- longitudinal direction(parallel to polarization).
- Transverse direction (Perpendicular to polarization).

When a mechanical stress is applied to a single sheet of piezoceramic in the longitudinal direction (parallel to polarization), a voltage is generated which tries to return the piece to its original thickness. Similarly when a stress is applied to the sheet in a transverse direction (perpendicular to polarization),a voltage is generated which tries to return the piece to its original length and width. A sheet bonded to a structural member which is stretched or flexed will induce electrical generation. Figure 2.4 and figure 2.5 shows longitudinal and transverse generators respectively. To increase the output of piezogenerator, we can connect number of

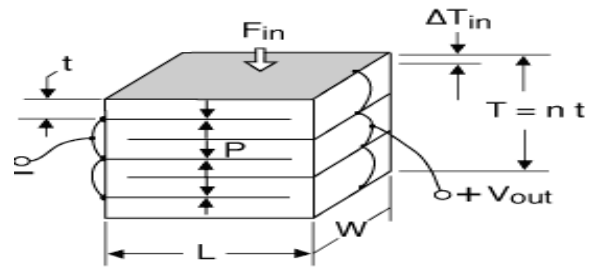

Fig2.6: Multi-Layer Stack Generator

The stack shown in figure 2.6 comprises large number of piezo layers, and is a very stiff structure with a high capacitance .It is suitable for handling high force and collecting a large quantity of charge efficiently.

As shown in figure 2.7 Generally, a piezo generator must deliver a specified current and voltage ,which determines its operating point on the voltage verses current line. Maximum power extraction for a particular application occurs when the generator delivers the required voltage at one half is closed circuit current. All other generators satisfying the design criteria will be larger, heavier and require more power input.

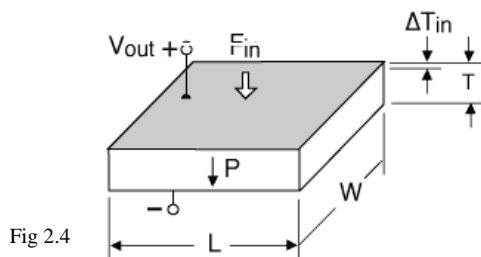

Fig 2.4  
 Longitudinal(d33)Generator

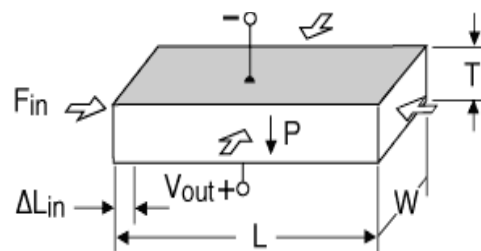

Fig.2.5Transverse (d31) generator

Piezoelectric transducers having same model number are in parallel. At the output of combined piezoelectric transducer we can get AC voltage .it is obviously more than single piezoelectric transducer .the multilayer piezoelectric transducer will be worked as shown in figure 2.6

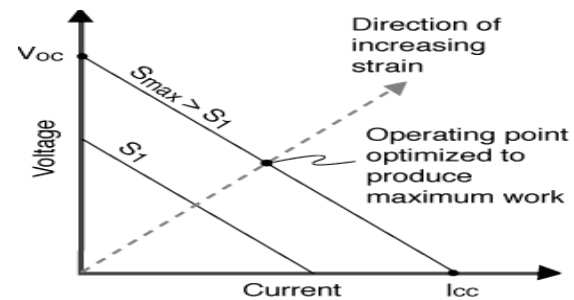

Fig2.7: Piezo Generator Performance  
 (Voltage versus Current Diagram)

### III.Experimental Setup, Results and Conclusion

For shoe generator we can apply piezo vibrations to the following regulation circuit diagram(figure3.1).The schematic of power harvesting circuit is shown in figure 3.2

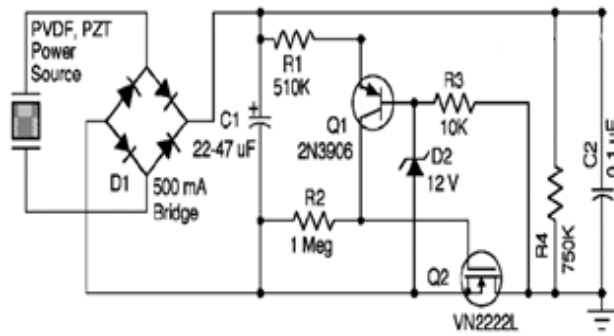

Fig 3.1 Voltage Regulation Circuit

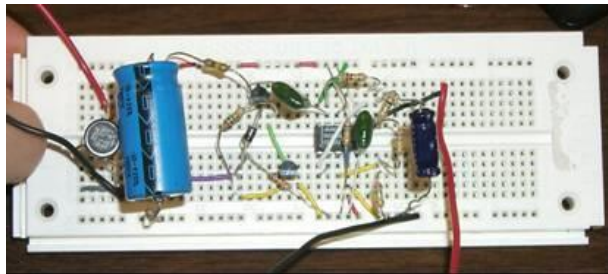

Fig.3.2Schematic of Power Harvesting Circuit

This experiment investigates the possibility of harvesting power from the vibration of structure such as piezoelectric shoe .In order to simulate the vibration of piezoelectric transducer an digital storage oscilloscope was attached to the output of piezoelectric transducer. The input signal is used as for the experiment shown in figure 3.2 along with the magnitude of the vibrations measured at the digital storage oscilloscope. Produced energy by the PZT can be store using two different ways:the first is in capacitor that allows for immediate access to the store energy and the second is in the nickel metal hydride battery.

For the first method of storage can be use the circuit shown in figure 3.1 It has modified from a circuit designed for a self-powered RF tag[3].And the second method used a nickel metal hydride button cell battery to store the energy produced by the PZT as shown in following figure 3.3.

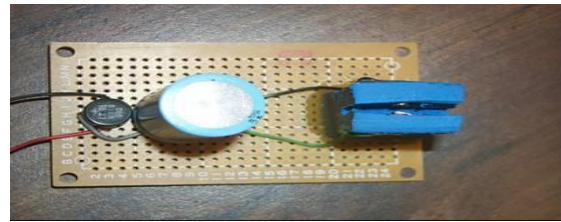
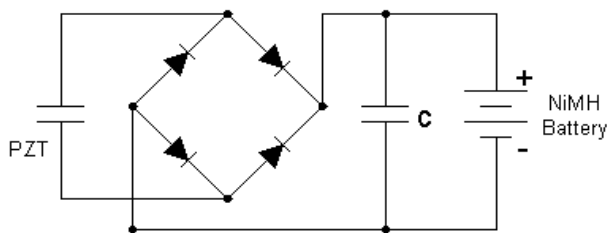

Fig 3.3Schematic of Battery charging circuit.

### Conclusion

From the above discussion we will conclude that piezo elements are excellent for dynamic or transient motion and force sensing. They are used as strain gages for easy and rapid determination of dynamic strains in structures due to their extremely high signal or noise ratios (on the order of 50 times that of wire strain gages).They require on power input since they generate their own power. In fact this is why they are now considered useful as energy harvesting and scavenging devices. They are small enough that they will not materially affect the vibrational characteristics of most structures.

### Acknowledgement

This research project would not have been possible without the support of my mentor ,guide,teachers and friends.I am thankful to all the individuals who encouraged and helped me directly and indirectly to carry this work .Their continuous invaluable knowledgably guidance throughout the course of this study helped me to complete the work up to this stage and hope will continue in further research.

### References

1. ZdenekHadas, VladislavSingule, StanislavVechet and CestmirOndrusek “Development of Energy Harvesting Sources for Remote Applications as Mechatronic systems”14th International Power Electronics and Motion Control Conference, EPE- PEMC
2. Ding Hun & Ville Kaajakari “MICROSTRUCTURED POLYMER FOR SHOE POWER GENERATION” Transducers 2009, Denver, CO, USA, June 21-25, 2009
- 3.M. Duffy, D. Carroll,” Electromagnetic generators for power harvesting” 2004 35th Annualize Power Electronics Specialists Conference.
4. K.Aminian,”Foot worn inertial sensors for gait assessment and rehabilitation based on motorized shoes”33rd Annual International Conference of the IEEE EMBS Boston, Massachusetts USA, August 30 - September 3, 2011

5. Loreto Mateu and Francesc Moll[“System-level simulation of a self-powered sensor with piezoelectric energy harvesting” 2007 International Conference on Sensor Technologies and Applications.
6. J. G. Rocha, L. M. Gonçalves, P. F. Rocha, M. P. Silva, and S. Lanceros-Méndez,” Energy Harvesting From Piezoelectric Materials Fully Integrated in Footwear” IEEE TRANSACTIONS ON INDUSTRIAL ELECTRONICS, VOL. 57, NO. 3, MARCH 2010.
7. Lu Chao, Chi-Ying Tsui and Wing-Hung Ki” A Batteryless Vibration-based Energy Harvesting System for Ultra Low Power Ubiquitous Applications.
8. Bhim singh ,BrijN.singh,AmbrishChandra,Dwaraka Kothari senior members ,IEEE,AshishPandey student member, IEEE”Review of single phase improved quality AC-DC converter.



Ms. Kamble Sushama Baburao  
Student M Tech (Electronics)  
Rajarambapu Institute of  
Technology,  
Rajaramnagar, Sakharale-415416  
Email  
ID: sush.06kamble@gmail.com