

## PAPR REDUCTION OF OFDM SIGNAL USING TURBO CODING AND SELECTIVE MAPPING

Suchita Chatterjee<sup>1</sup>, Neelam Dewangan<sup>1</sup>, Mangal Singh<sup>1</sup>

<sup>1</sup>Chhatrapati Shivaji Institute of Technology, Durg, (C.G.) India

[suchitachatterjee@csitdurg.in](mailto:suchitachatterjee@csitdurg.in), [neelamdewangan@csitdurg.in](mailto:neelamdewangan@csitdurg.in), [mangalsingh@csitdurg.in](mailto:mangalsingh@csitdurg.in)

### ABSTRACT

Orthogonal frequency division multiplexing (OFDM) technique is a promising technique to offer high data rate and reliable communications over fading channels. The main implementation disadvantage of OFDM is the possibility of high peak to average power ratio (PAPR). This paper presents a novel technique to reduce the PAPR using turbo coding and selective mapping (SLM). We show that the probability of the PAPR of OFDM signal with 128 subcarriers exceeding 7 dB can be reduced from 70% to 0.25% with bit error rate (BER) of  $6 \times 10^{-5}$  at signal to noise ratio (SNR) 4 dB.

### 1. INTRODUCTION

OFDM, orthogonal frequency division multiplexing, is a multicarrier communication technique, where a single data stream is transmitted over a number of lower rate subcarriers. OFDM has become tangible reality, it has been employed for wire-line communications and also has been employed in wireless local area network (WLAN) e.g. IEEE 802.11. Other applications of OFDM are digital audio broad-casting (DAB) and digital video broadcasting (DVB).

Unfortunately, OFDM has the drawback of a potentially high peak to average power ratio (PAPR). Since a multicarrier signal consists of a number of independent modulated subcarriers that can cause a large PAPR when the subcarriers are added up coherently.

To reduce the PAPR different techniques were proposed. These techniques can be categorized into the following, clip-ping and filtering [1], coding [2], phasing [3], scrambling [4], interleaving [5], and companding [6].

In this paper we propose and examine a technique for reducing the probability of a high PAPR, based on part on a method proposed in [7] and [8]. This technique is a variation of selective mapping (SLM) [7], in which a set of independent sequences are generated by some means from the original signal, and then the sequence with the lowest PAPR is transmitted. To generate these sequences we use turbo en-

coder. Using turbo coding will offer two advantages, significant PAPR reduction and astonishing bit error rate (BER) performance.

The rest of the paper is organized as follows: The problem of high PAPR of OFDM signal is briefly defined in section 2. Section 3. introduces the proposed technique. Some simulation results are shown in section 4. Finally, the conclusions are drawn in section 5.

### 2. PROBLEM DEFINITION

We suppose an OFDM transmission scheme, where a block of  $N$  complex symbols is first over-sampled using over sampling factor  $J$  and then transformed into time domain using the inverse fast Fourier transform (IFFT). This results in the following signal:

$$x(t) = \sqrt{\frac{1}{N}} \sum_{k=0}^{N-1} s_k e^{j2\pi J \frac{kt}{N}} \quad (1)$$

where  $s_k$  is the data to be transmitted and  $1 < t < NJ$ . The

PAPR is defined as the ratio between the maximum power occurring in OFDM symbol to the average power of the same OFDM symbol:

$$PAPR = \frac{\max |x(t)|^2}{E[|x(t)|^2]} \quad (2)$$

where  $E[.]$  denotes expectation.

When the OFDM signal with high PAPR passes through a non-linear device, (power amplifier working in the saturation region), the signal will suffer significant non-linear distortion [9]. This non-linear distortion will result in in-band distortion and out-of-band radiation. The in-band distortion causes system performance degradation and the out-of-band radiation causes adjacent channel interference (ACI) that affects systems working in the neighbor bands. To lessen the signal distortion, it requires a linear power amplifier with large dynamic range. However, this linear power amplifier has poor efficiency and is so expensive.



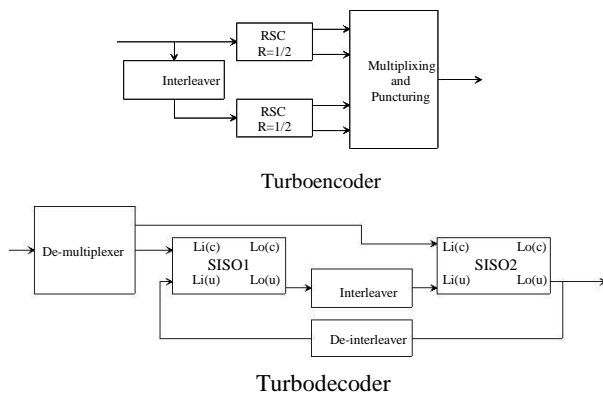

Fig. 1. Turbo system

### 3. SELECTIVE MAPPING USING TURBO CODING

The probability that, the PAPR of the OFDM signal exceeds a certain threshold  $\lambda$  is given by

$$Pr\{PAPR > \lambda\} = 1 - (1 - e^{-\lambda})^N \quad (3)$$

In SLM it is assumed that,  $U$  statistically independent alternative sequences, which represent the same information, are generated by some suitable means. The sequence with the lowest PAPR is selected for transmission.

The probability that, the lowest PAPR  $\lambda_j$  exceeds a certain threshold  $\lambda$  is given by

$$Pr\{\lambda_j > \lambda\} = (Pr\{PAPR > \lambda\})^U \quad (4)$$

To generate these sequences linear feedback shift register (LFSR) is used [10]. A LFSR is used to transform the data before it is mapped to the orthogonal channels. Different sequences are generated by inserting different bits labels at the beginning of the data. This results in  $U = 2^m$  different sequences, where  $m$  is the length of the inserted bits.

Turbo codes [11] are parallel concatenated convolution codes in which the information bits are first encoded by a recursive systematic convolutional (RSC) code and then, after passing the information bits through an interleaver, are encoded by a second RSC code. Turbo decoder is used to recover the transmitted signal at the receiver side. The Turbo decoder consists of two soft input soft output (SISO) modules [12], an interleaver and de-interleaver. Figure 1 shows a turbo system, turbo encoder and decoder.

In this paper, instead of using LFSR, we use turbo encoder to generate different sequences and the sequence with the lowest PAPR is selected for transmission. The different sequences are generated by inserting different bits labels at the beginning of the data. Figure 2 shows the transmitter side of an OFDM system, where the turbo coding and SLM are used for PAPR reduction. For each bits labels  $b_i$

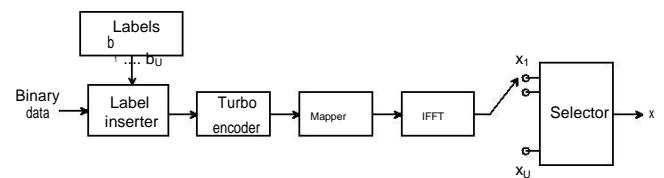

Fig. 2. System model

$i = 1, 2, \dots, U$ , where  $b_i$  a sequence of  $m$  bits, the turbo encoder will generate a sequence  $x_i, i = 1, 2, \dots, U$ . The sequence that has the lowest PAPR will be selected for transmission. At the receiver side, the receiver does not need any side information and the bits labels are discarded after decoding.

### 4. SIMULATION RESULTS

The PAPR reduction and BER performances of the proposed scheme are examined by computer simulation. In the simulation we consider an OFDM signal with  $N = 128$  subcarriers, Quadrature phase shift keying (QPSK) mapping, and turbo code with two RSC encoders each has a constraint length  $K = 4$  with generator polynomial  $15/17$ , where  $g_1/g_2$  represents the forward/backward generator polynomials in octal base. Puncturing is used to increase the overall code rate to  $R = \frac{1}{2}$ . To obtain accurate PAPR calculations the signal is over sampled,  $J = 8$ . Additive white gaussian noise (AWGN) channel is assumed. At the receiver side logarithmic maximum a posteriori probability (log-MAP) algorithm is used to implement the SISO modules.

Figure 3 shows the complementary cumulative distribution function (CCDF) of the PAPR of the OFDM signal, where turbo coding and SLM are used for PAPR reduction. The CCDF of the PAPR without SLM is also shown ( $U=1$ ). Clearly, the probability of high PAPR is reduced significantly as the number of sequences increases. When  $U = 1$ , the probability of the PAPR exceeding 7 dB is 70% and with turbo coding and SLM, with  $U = 32$ , the probability of the PAPR exceeding 7 dB can be reduced to 0.25%. The simulation results agree with the results obtained by the approximation in equation (4) with small differences. These small differences are due to the fact that, equation (4) was derived with the assumption that, the samples are mutually un-correlated which is not true any more when over sampling is applied.

The BER performance of the proposed scheme is also shown in Figure 4 for number of iterations 1, 2 and 5. With 5 iterations the probability of bit error is reduced to  $6 \times 10^{-5}$  at SNR 4 dB.

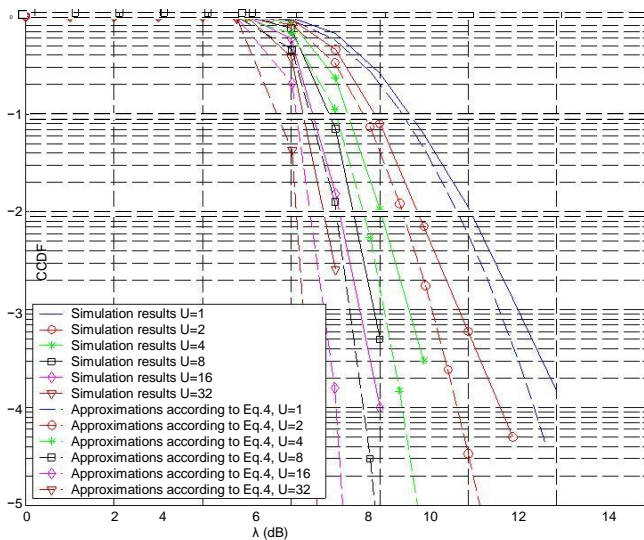

Fig. 3. PAPR performance.

### 5. CONCLUSIONS

We have shown that, Turbo coding and SLM can be combined to reduce the PAPR of OFDM signal with quite moderate additional complexity. The advantage of the proposed scheme is that, the Turbo encoder is used for two purposes, error correction and PAPR reduction. This reduces the hard-ware complexity of the system.

### 6. REFERENCES

- [1] X. Li and L. J. Cimini Jr., "Effects of clipping and filtering on the performance of OFDM," IEEE Communication Letters, pp. 131-133, May 1998.
- [2] A. E. Jones, T. A. Wilkinson and S. K. Barton, "Block coding scheme for reduction of peak to mean envelope power ratio of multicarrier transmission schemes," Electronic Letters, pp. 2098-2099, Dec. 1994.
- [3] V. Tarokh and H. Jafakhani, "On the computation and reduction of peak to average power ratio in multicarrier communications," Proc. IEEE 53<sup>rd</sup> Vehicular Technology Conference, vol.2, pp. 37-44, Jan 2000.
- [4] P. Van Eetvelt, G. Wade and M. Tomlinson, "Peak to average power reduction for OFDM schemes by selective scrambling," Electronic letters, vol. 32, pp. 1963-1994, Jan 2000.
- [5] A. D. S. Jayalath and C. Tellambura " The use of interleaving to reduce the peak to average power ratio of an OFDM signal," Global Telecommunication

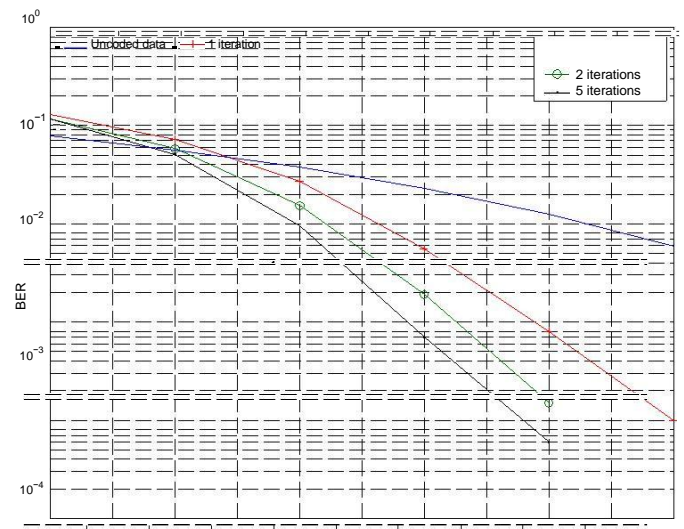

Fig. 4. BER performance.

Conference, 2000, GLOBECOM '00. IEEE, vol. 1, pp. 82-86, Nov.-1 Dec. 2000.

- [6] Xiao Huang, Jianhua Lu, Justin Chuang, and Junli Zheng, "Companding transform for the reduction of peak to average power ratio of OFDM signal," IEEE Trans. On Commun. vol. 48, pp. 835-839, May 2001.
- [7] R. Bauml, R. Fischer and J. Huber, "Reducing the peak to average power ratio of multicarrier modulation by selected mapping," Elect. Letts., vol. 32, pp. 2056-2057, Oct. 1996.
- [8] N. Carson, T. A. Gulliver, "PAPR reduction of OFDM using selected mapping, modified RA codes and clipping", in Proc. IEEE VTC, vol.2, pp. 1070-1073, Sep. 2002.
- [9] S. Merchan, A. Garcia Armada and J. L. Garcia, "OFDM performance in amplifier nonlinearity," IEEE Trans. On Broadcasting , vol. 44 Issue:1, pp. 106-114, Mar. 1998.
- [10] M. Breiling, S. Muller-Weinfurter and J. Huber, "Peak-power reduction in OFDM without explicit side information," Proc. 5<sup>th</sup> Int. OFDM Workshop, Germany, pp- 28.1-28.4, 2000.
- [11] C. Berrou, A. Glavieux and P. Thitimajshima, "Near Shannon limit error correcting coding and decoding: Turbo Codes." in Proc. of ICC'93, (Geneva, Switzerland), pp. 1064-1070, May 1993.



